

November/December 2024 | mwr.com

Microwaves & RF[®]

*Emerging Tech
Fuels 2025's*

TOP TRENDS

Find the Right Part Faster



Designed by Engineers for Engineers, our **MAGPro**[®] RF Inductor and Choke Finder helps you find the optimal parts for your desired L@frequency or Z@frequency quickly, reducing your design cycle time.

Coilcraft's patent-pending **MAGPro** online inductor analysis tools are designed to enable inductor selection and circuit optimization based on sound engineering principles and measured data.

The RF Inductor/Choke Finder and Analyzer offers two search options. The L @ Frequency option identifies inductors suitable for your L, Q, and current requirements and displays

a full range of performance graphs including L, Q and ESR at frequency.

For RF choke applications, the Z @ Frequency tool searches thousands of part numbers for your desired impedance and lets you select the desired choke based on size, performance, or a combination of the two.

Reduce your design cycle time with confidence at www.coilcraft.com/tools.

Coilcraft[®]

WWW.COILCRAFT.COM

CONTENTS

NOVEMBER/DECEMBER 2024 | VOLUME 63, ISSUE 6

FEATURES

- 12** | 2025's TOP TRENDS:
 - Microwave Technologies
 - Artificial Intelligence & Machine Learning
 - Cognitive Radio Systems
 - IoT Sensors
 - O-RAN Technology

- 20** | The Intelligent Future of Spectrum Visibility (Part 2)

- 24** | 11 Myths About Machine Learning at the Edge

- 26** | The Basics of Radar Technology (Part 2)

DEPARTMENTS

- 4** | From the Editor
- 5** | Ad Index
- 6** | Watch & Connect @ *mwr.com*
- 8** | News
- 10** | Featured Products
- 29** | New Products

Cover photo: Chaleampun Tasvad_2182193323
iStock / Getty Images Plus

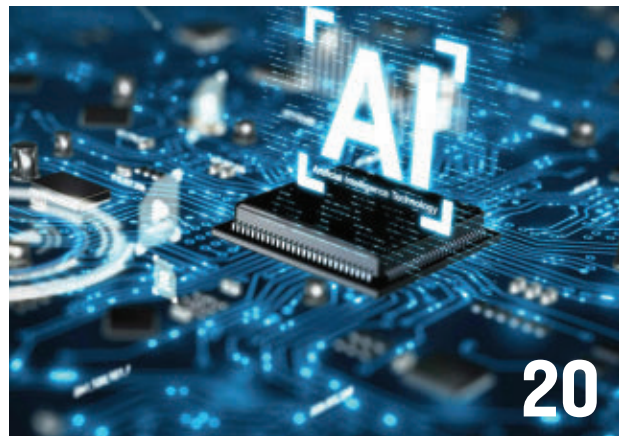



Looking Toward 2025 and Beyond

The future of RF and microwave technology depends on integration of emerging technologies like AI/ML, cognitive radio, O-RAN, and smarter IoT sensors.

AS WE STAND on the cusp of 2025, it's time to take stock of where we are with our ever-evolving world of wireless communication technology. The foundational technologies—those concerned with actual radios themselves—are well in hand. We have long since conquered the airwaves. We're surrounded day and night with signals that span the electromagnetic spectrum from HF to well into the mmWave range.

But even as we fill the spectrum with signals, we create other issues that cloud the future of the wireless communications industry. For one, we need to get smarter about how we use that physically limited, yet densely packed EM spectrum. Building out the infrastructure for cellular communications is incredibly expensive and difficult to manage. And we're transmitting enormous amounts of data with our radios that we need to keep secure.

When we consider the emerging technological trends to help us navigate the future of the wireless industry, it's not so much the foundational technologies that stand out. Rather, it's how we might augment them with new companion technologies that leverage today's powerful computation capabilities.

In this digital issue of *Microwaves & RF*, long-time industry observer and contributing editor Jack Browne takes a dive into four trends that we see shaping the industry in 2025 and in years to come. To start, when it comes to making sense of the sheer volume of signals and data they carry, **artificial intelligence and machine learning** will come to the fore. Algorithms can sort through multiple received signals to correct multipath effects. Machine learning will help with counter-jamming protection in electronic-warfare use cases, perhaps saving lives.

In a way, the obverse problem that comes with a dense spectrum is determining how to best utilize what's available. This is where **cognitive radio** comes in, enabling transceivers to be spectrum-aware and shift their output to unoccupied frequencies. It's accomplished by combining spread-spectrum and frequency-hopping radios that are guided by AI to efficiently use the airwaves.

Cybersecurity for the IoT/IIoT is a growing problem as more wireless-enabled sensors come online. This issue certainly affects civilians in smart homes, offices, and factories, but it's a huge



21156799 © Joanne Zhe | Dreamstime.com

concern for the defense establishment. The Pentagon is keenly aware of ensuring the security of the massive amounts of data involved in efforts to maintain readiness.

Lastly, there's the issue of the cost, complexity, and effort that goes into building communications infrastructure. One promising avenue to address these issues comes in the form of **open radio-access networks** (O-RAN). Under the auspices of the **O-RAN Alliance**, the telecom industry is making its way toward a redefinition of RAN methodologies. O-RAN seeks to improve interoperability between hardware and software from multiple vendors in hopes of lower network latencies, lower costs, and improved overall performance.

Of course, many other important tech trends are building momentum of late (the move to non-terrestrial networks in support of 6G comes to mind). But I hope that these snapshots of four key technologies will help point you toward the new year and the challenges they will bring. ■

David Maliniak

dmaliniak@endeavorb2b.com

EDITORIAL ADVISORY BOARD



RODGER H. HOSKING
Director of Sales,
Mercury Systems



DONNA MOORE
CEO and chairwoman,
LoRa Alliance



NIZAR MESSAOUDI
6G Program Manager,
Keysight Technologies



DAVID VYE
Senior Product
Marketing Manager
AWR Software
Cadence Design Systems



DAVE DURBIN
Director of Engineering
& Vice President
for Quantic PMI
(Planar Monolithics)



TONY MESSINA
Director of Design
Engineering,
Aerospace & Defense,
Analog Devices
Integrated Solutions



TONY TESTA
Director-Marketing,
Wireless Connectivity
Business Unit, Qorvo



GIORGIA ZUCHELLI
Product Manager,
RF and Mixed-Signal,
MathWorks

AD INDEX

COILCRAFT, INC......2
www.coilcraft.com

COPPER MOUNTAIN TECHNOLOGIES..... 32-33
www.coppermountaintech.com

DB CONTROL..... 9
www.dbcontrol.com

DS INSTRUMENTS30-31
www.ds instruments.com

POLYFET RF DEVICES, INC......7
www.polyfet.com

EDITORIAL

Market Leader - Electronic & Mechanical Group: Michelle Kopier
mkopier@endeavorb2b.com

Senior Content Editor: Bill Wong
bwong@endeavorb2b.com

Executive Editor: David Maliniak
dmaliniak@endeavorb2b.com

Managing Editor: Roger Engelke
rengelke@endeavorb2b.com

Editor-at-Large: Alix Paultre
apaultre@endeavorb2b.com

Senior Staff Writer: James Morra
jmorra@endeavorb2b.com

Technical Editor: Jack Browne
jack.browne@citadeleng.com

ART & PRODUCTION

Group Design Director: Anthony Vitolo

Art Director: Jocelyn Hartzog

Production Manager: Sam Schulenberg

Ad Services Manager: Deanna O'Byrne

AUDIENCE MARKETING

User Marketing Manager: Debbie Bouley
dbouley@endeavorb2b.com

Article Reprints:
reprints@endeavorb2b.com

LIST RENTAL

Smartreach Client Services Manager:
Kelli Berry, kberry@endeavorb2b.com

DIGITAL & MARKETING

VP Digital & Data Innovation: Ryan Malec

SALES

AL, AR, SOUTHERN CA, CO, FL, GA, HI, IA, ID, IL, IN, KS, KY, LA, MI, MN, MO, MS, MT, NC, ND, NE, OH, OK, SC, SD, TN, UT, VA, WI, WV, WY, CENTRAL CANADA:

Samantha Nelson,
snelson@endeavorb2b.com

AZ, NM, TX: Gregory Montgomery
gmontgomery@endeavorb2b.com

CT, DE, MA, MD, ME, NH, NJ, NY, PA, RI, VT, EASTERN CANADA:

Elizabeth Eldridge
eeldridge@endeavorb2b.com

AK, NORTHERN CA, NV, OR, WA, WESTERN CANADA, AUSTRIA, BELGIUM, FRANCE, GERMANY, LUXEMBURG, NETHERLANDS, PORTUGAL, SCANDINAVIA, SPAIN, SWITZERLAND, UNITED KINGDOM:

Stuart Bowen,
sbowen@endeavorb2b.com

ITALY: Diego Casiraghi,
diego@casiraghi-adv.com

PAN-ASIA: Helen Lai
helen@twoway-com.com

PAN-ASIA: Charles Liu
liu@twoway-com.com



ENDEAVOR BUSINESS MEDIA, LLC
30 Burton Hills Blvd., Suite 185,
Nashville, TN 37215 | 800-547-7377

CEO: Chris Ferrell

COO: Patrick Rains

CRO: Paul Andrews

Chief Digital Officer: Jacquie Niemiec

Chief Administrative and Legal Officer:
Tracy Kane

Chief Marketing Officer: Amanda Landsaw

EVP, Design & Engineering Group:
Tracy Smith

Microwaves & RF Magazine ID Statement 2024:

Microwaves & RF, ISSN 2162-1411 online, is published 6 times a year [January/February, March/April, May/June, July/August, September/October, November/December] by Endeavor Business Media, LLC, 201 N Main St, 5th Floor, Fort Atkinson, WI 53538.

POSTMASTER: Send address changes to Microwaves & RF, PO Box 3257, Northbrook, IL 60065-3257.
SUBSCRIPTIONS: Publisher reserves the right to reject non-qualified subscriptions. Subscription prices: U.S. \$68.75 per year; Canada/Mexico \$81.25 per year; All other countries \$93.75 per year. All subscriptions are payable in U.S. funds. Send subscription inquiries to Microwaves & RF, PO Box 3257, Northbrook, IL 60065-3257. Customer service can be reached toll-free at 877-382-9187 or at microwavesRF@omeda.com for magazine subscription assistance or questions.

Printed in the USA. Copyright 2024 Endeavor Business Media, LLC. All rights reserved. No part of this publication may be reproduced or transmitted in any form or by any means, electronic or mechanical, including photocopies, recordings, or any information storage or retrieval system without permission from the publisher. Endeavor Business Media, LLC does not assume and hereby disclaims any liability to any person or company for any loss or damage caused by errors or omissions in the material herein, regardless of whether such errors result from negligence, accident, or any other cause whatsoever. The views and opinions in the articles herein are not to be taken as official expressions of the publishers, unless so stated. The publishers do not warrant either expressly or by implication, the factual accuracy of the articles herein, nor do they so warrant any views or opinions by the authors of said articles.



Video ▶ Building a Modular RF Testing Solution

Coming down the escalator from the lobby to the show floor at June's [International Microwave Symposium](#), it was hard to miss [MilliBox's](#) booth and its display of RF anechoic chambers. In this video, our colleague at *Electronic Design*, Bill Wong, interviews Jean Marc Laurent, MilliBox's VP of engineering about his company's modular [MBX0x anechoic chamber](#). The compact chambers comprise 24-in. modular sections that can be combined in various configurations.

www.mwr.com/55245540



Video ▶ Empower Smart-Home Applications with Advanced Connectivity

Smart homes offer functionality for homeowners to monitor and control a wide range of useful applications while improving energy efficiency and security. Qorvo enables faster communications, increased network capacity, and solution scalability with its latest smart-home and IoT solutions. Especially useful is the company's [ConcurrentConnect](#) technology, which provides simultaneous operation of single and multi-protocol smart devices over a single home network. The company's [QPG6100](#) is a multi-standard Smart Home Communications Controller for ultra-low-power wireless communication, while its [QPG7015M](#) is presented as the first transceiver with real-time concurrency, allowing for seamless Bluetooth Low Energy Mesh and Zigbee/Thread network management simultaneously.

www.mwr.com/55235124



Electronica 2024 Wrap-Up

The [electronica 2024 trade show](#), held in Munich, Germany, was once again one of the largest gatherings of electronic technology and product vendors in the world. With the show now in the rearview mirror, our editors who covered it, including Editor-at-Large [Alix Paultre](#), offer up some of the product highlights.

www.mwr.com/55241221



For Under the Tree: RF Development & Evaluation Kits

Not everyone loves the holidays, but just about everyone likes receiving gifts. You could always go with that cheesy sweater or ugly tie as a gag gift. But for the RF engineers on your shopping list, why not hit them with something that'll let them exercise their creative muscles and keep them busy until they head back to work? When they do, perhaps it'll be with a fresh idea for an upcoming design project. To that end, here's a smattering of some of the RF-related development kits and evaluation boards out there for your favorite wireheads.

www.mwr.com/55241677

 www.facebook.com/microwavesrf

 [@MicrowavesRF](https://twitter.com/MicrowavesRF)

 linkedin.com/groups/3848060/profile

 www.youtube.com/@engineeringtvEBM

Broadband RF power transistors, modules, and evaluation amplifiers: Polyfet RF Devices offers them all.

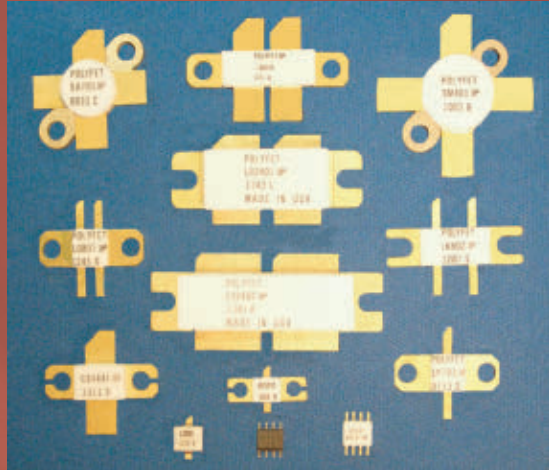

GaN: 28VDC and 48VDC, up to 3GHz, up to 160W, single-ended and push-pull.

LDMOS: 5-50VDC, up to 2.7GHz, up to 2kW, single-ended and push-pull.

VDMOS: 12.5-50VDC, up to 1GHz, up to 400W, single-ended and push-pull.

Broadband RF power modules:
Utilize GaN and D-MOS technologies.
24-48VDC, up to 1260MHz, up to 350W CW,
various case sizes and RF connection types.
Custom design requests welcomed.

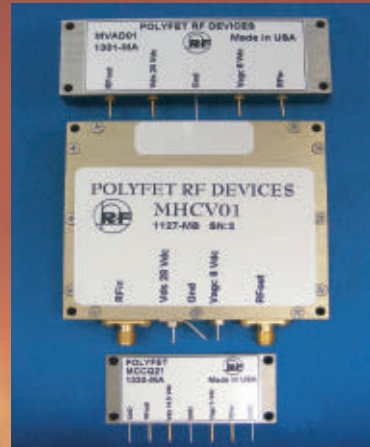
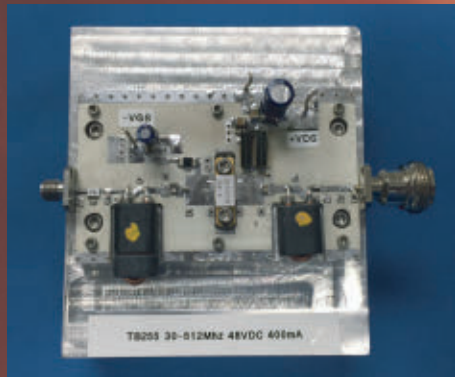

Various evaluation amplifiers available:
Displayed here is the TB255. It demonstrates the GX3442 (GaN) putting out 100W CW, 19dB across 30-512MHz with 48VDC supply.



Your
Power
MOSFET
People

polyfet rf devices

www.polyfet.com

TEL (805) 484-4210



Wi-Fi HaLow Gains Community Forum and Open-Source GitHub Repositories

A collection of assets, tools, and resources will spur worldwide development and growth for the Wi-Fi HaLow variant.

WITH THE LAUNCH of multiple open-source GitHub repositories and a community forum, [Morse Micro](#) now offers a collection of assets, tools, and resources in support of the Wi-Fi HaLow global developer community. Both the repositories and forum are available for free, catering to engineers, developers, and tech enthusiasts interested in advancing Wi-Fi HaLow ([IEEE 802.11ah](#)) technology.

As of today, Morse Micro's [GitHub repositories](#) contain the software and tools necessary to bring up Wi-Fi HaLow on Linux-based projects. Additionally, the [Morse Micro community](#) is a dedicated platform where users can engage in discussions, share knowledge, seek advice, troubleshoot, and contribute to Wi-Fi HaLow-related projects. The forum also serves as a space to discuss broader connectivity topics, facilitating collaboration across the global Wi-Fi HaLow community.

By launching these resources, Morse Micro hopes not only to advance Wi-Fi HaLow technology, but also foster a culture of continuous learning and development. With these centralized platforms, developers and Morse Micro's partners can access the

latest software releases, seek expert guidance, and collaborate with peers to drive innovation. ■

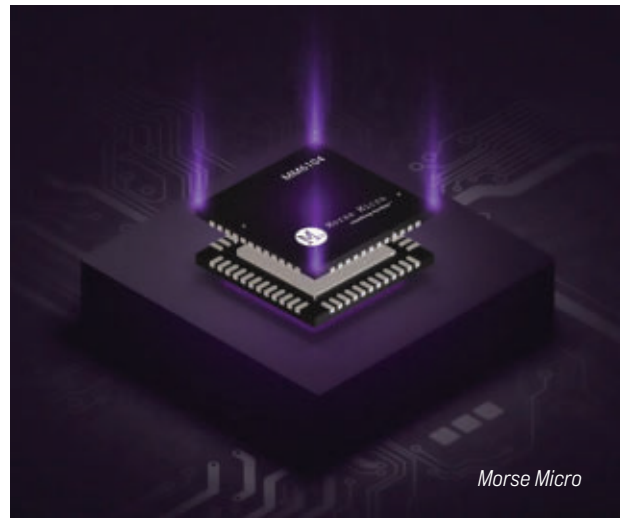

VADR Radar System Adds C-Band Range

THE U.S. AIR FORCE Advanced Radar Threat System Variant3 (ARTS-V3) system is extending its spectral reach into C-band with the latest advances from [Lockheed Martin](#). The variable-aperture digital radar (VADR, *see figure*) now includes C-band technology along with its existing X-band



Lockheed Martin Corp.

frequency coverage for increased long-range adversarial threat coverage. The upgraded radar system adds to the detection capabilities of terrestrial surface-to-air-missile (SAM) radar defense systems.

The [ARTS-V3 VADR system](#) incorporates dual polarization capabilities and shares some electronic design with the Sentinel A4 radar system developed by Lockheed Martin. In addition to use by the U.S. Air Force, the C-band line-replaceable units (LRUs) can be employed by the U.S. Army and other military services within environments where commercial S-band electromagnetic (EM) interference is a concern.

By incorporating software-defined-radio (SDR) technology, the ARTS-V3 VADR system can process multiple threats within the X- and C-band frequency ranges rather than being limited to a single threat signal source, quickly adapting to changing threat environments. The system provides advanced early warning of threats and helps develop counter-target responses. ■

Now You Can Cover Entire 2-40 GHz Spectrum with Two dB Control Amplifiers

**New TWTAs & GaN MPM for Radar, EW Simulation,
ECM Transmitters, Test & Measurement, Data Links,
Secure SATCOM**



dB-8015 GaN Microwave Power Module

- Very Wideband (2.0 to 18 GHz), 200 W CW
- Liquid Cooled for excellent reliability
- Small and lightweight to meet SWaP requirements
- Perfect for high-performance MIL-STD applications



Scan for dB-8015
MPM Datasheet



dB-4051 & dB-4051A TWT Amplifiers

- K/Ka Band
- 18 to 40 GHz, 50/60W CW (dB-4051)
- 17.5 to 40 GHz, 40/50W CW/Pulse (4051A)
- Rackmount configuration



Scan for dB-4051
TWTA Datasheet



Scan for dB-4051A
TWTA Datasheet

dB Control
a HEICO company
Reliability by Design®



www.dBControl.com

For specs and customization info, call **510-656-2325**
or email info@dBControl.com

Platform Props Up Prototyping with IoT SoCs for Energy-Harvesting Apps

Ride the “ambient IoT” wave with a kit for prototyping battery-less IoT devices that grab power from magnetic/electric fields, light, heat, kinetic energy, and sound.

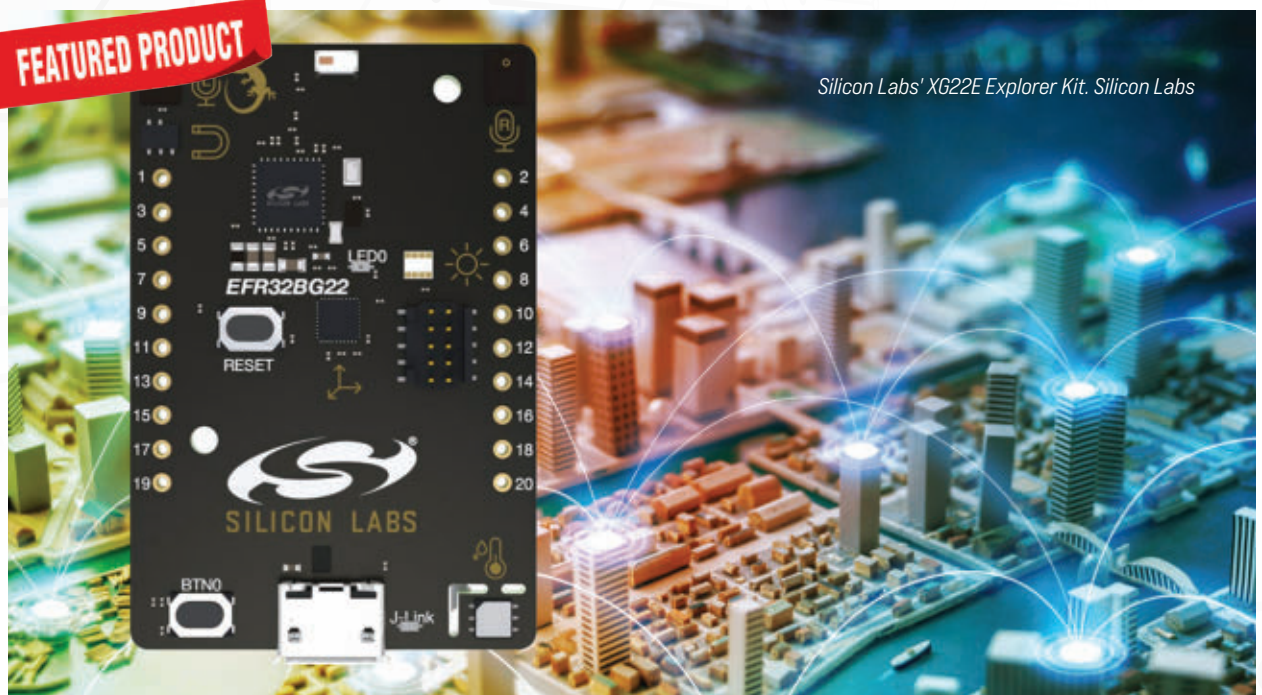

The Overview: A Development Kit for BLE IoT SoCs

A development kit borne of a collaboration between [Silicon Labs](#) and [e-peas](#) makes it easier to create concepts and build rapid prototypes of what's now termed “ambient IoT” devices. Silicon Labs' [EFR32xG22E Explorer Kit](#) features a USB interface, an on-board [SEGGER J-Link debugger](#), an LED and button for a UI, and support for add-on hardware boards via a mikroBUS socket and Qwiic connector.

Who Needs It & Why: Smart-Home and Building Apps

IoT devices prototyped with the SiLabs Explorer Kit will have applications in Zigbee-connected smart-home settings, such

as doors, faucets, and switches. Similar uses might be found in smart buildings, using kinetic-pulse power harvesting for doorknobs and light switches. Others include indoor solar-powered TV remotes and computer keyboards that have need of energy-efficient Bluetooth LE SoCs.

Such devices might also be used in tire-pressure monitor sensors, asset tracking, electronic shelf labels, factory automation, predictive maintenance, and agriculture.

Under the Hood: Wireless SoCs for Energy Harvesting IoT Devices

The kit is intended for use with the company's [xG22E family of wireless SoCs](#), notable for their ability to operate within the ultra-low-power envelope demanded of battery-less energy-harvesting appli-

cations. Touted as the company's most energy-efficient SoCs to date, the [BG22E](#), [MG22E](#), and [FG22E](#) devices serve Bluetooth LE, 802.15.4-based, or proprietary 2.4-GHz applications.

e-peas contributed the energy-harvesting shields for the kit. Each of the shields, tuned for different energy sources and energy-storage technologies, are custom-fit to slot onto the SiLabs Explorer Kit. One enables experimentation with alternative battery chemistries and supercapacitors. A second is geared for kinetic/pulse harvesting and uses e-peas' [AEM0300 power-management IC \(PMIC\)](#) for power buck. The third shield, which employs e-peas' [AEM13920 PMIC](#), allows for experimentation with dual power-harvesting sources simultaneously.

70-GHz SI Test Assembly System Now Has Eval Kit

EARLIER THIS YEAR, Samtec released its Bulls Eye high-performance test assemblies for frequencies as high as 90 GHz. The assemblies, which help shrink evaluation boards and trace lengths, serve test applications for SerDes characterization, clock/data recovery, mmWave radar, automated test equipment, and FR2 5G networks.

To aid engineers in evaluating the Bulls Eye assemblies, Samtec offers a **70-GHz Bulls Eye signal-integrity (SI) evaluation kit**. It gives system designers, RF engineers, and SI engineers a means of testing the double-row Bulls Eye system to ensure its performance in their specific applications.

The 70-GHz Bulls Eye SI Evaluation Kit (REF-213864-01) is a single-PCB system with a compact form factor. Each PCB includes one BE70B (BE70B-J-S-2-04) compression interface that provides easy mating and eliminates soldering. Each kit comes with four BE70C (BE70C-S-185P-2-02-0305) Bulls Eye cable assemblies.

The board routes high-frequency referential signals (a total of eight) from the BE70A to precision RF compression-mount connectors. The kit delivers optimized SI performance thanks to the company's Final Inch BOR PCB trace routing.

With the evaluation kit, users can perform time-domain measurements through direct connections to time-domain reflectometers or time-domain transmissions, or frequency-domain measurements through direction connection to vector network analyzers. It can be used with IC characterization kits, 112-Gb/s PAM4 transceiver development kits, and FPGA evaluation and development kits.



Samtec | Generated by AI

Tri-Radio IoT Module Offers Broad Wireless Compatibility

THE MAYA-W4, a cost-effective tri-radio module developed by **u-blox** that offers broad wireless connectivity, supports dual-band Wi-Fi 6, Bluetooth Low Energy 5.4, and 802.15.4 (for Thread supporting Matter). Combining three

important wireless technologies in a compact, power-efficient module with an operating temperature range from -40 to +85°C, the MAYA-W4 addresses the growing demand for reliable, robust, and secure connectivity.

From applications like enabling **low-energy mesh networks for smart homes**, or providing **high-speed Wi-Fi 6 connectivity** for industrial tools, the MAYA-W4's small size and robust design suit it for space-constrained applications.

With comprehensive global certifications to ensure seamless deployment across regions, it also alleviates network congestion and enhances power efficiency, making it a good fit in industrial environments, with 802.15.4 to enable low-power IoT and mesh networking. It's compatible with a selection of antenna variants, embedded or connected.

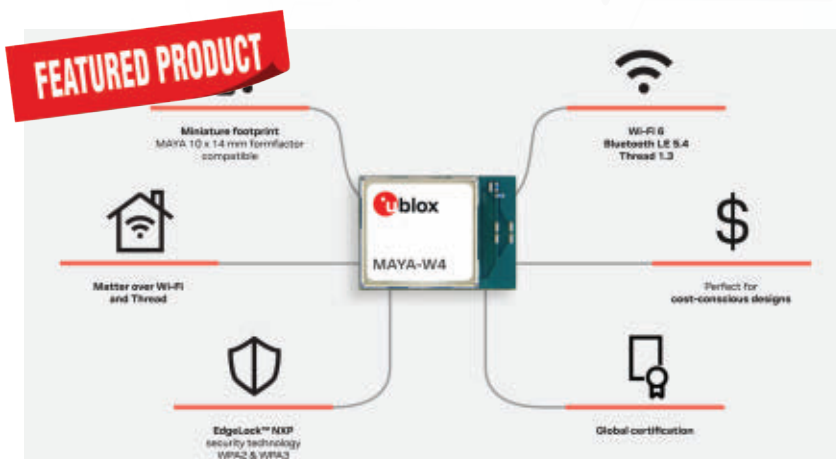

The u-blox MAYA-W4 combines Wi-Fi 6, Bluetooth LE 5.4, and 802.15.4. u-blox



2025'S TOP TRENDS

Microwave Technologies

Electronic products enjoy the greatest benefits by combining RF/microwave functions with emerging technologies, such as AI/ML, cognitive radio, IoT, and Open RAN.

by **Jack Browne**,
Technical Contributor

HIGH-FREQUENCY ELECTRONIC designs were once dominated by large transmitters and receivers, often providing communications and radar systems with limited voice and data capabilities. But ongoing trends of heightened integration and increasing miniaturization are combining wireless functionality with many emerging and innovative electronic technologies. These advances make optimum use of available frequency spectrum even as they tackle higher operating frequencies.

Industry trends in RF/microwave design feature innovative integration of supporting technologies for added functionality without significantly increasing size, weight, or power consumption. These companion technologies include **artificial intelligence (AI)**, **machine learning (ML)**, **cognitive radio (CR)**, **Open Radio Access Network (O-RAN)** equipment, and **Internet of Things (IoT) sensors**. Integrating multiple technologies provides benefits in many industries, including commercial, industrial, medical, military, and deep space users.

Trends for electronic designs with reduced size, weight, and power (SWaP) have been driven by aerospace and defense (A&D) requirements. However, demand for products tracking such trends has carried over to many other industries, resulting in highly miniaturized, densely integrated designs that include those for small signal and power circuits.

Components like newer system-in-package (SiP) and system-on-chip (SoC) devices as well as well-established integrated circuits (ICs) and discrete components support the miniaturization. Still,

achieving printed-circuit boards (PCBs) with dense circuit layouts require thoughtful circuit material selection due to considerations such as thermal management and circuit material expansion and contraction with temperature and humidity.

Integration of RF/microwave circuits and systems with emerging electronic technologies like AI/ML, CR, IoT, and O-RAN requires a system-level view of available resources to enable them to work together. The different technologies working within a system are often related in operation; e.g., how AI/ML technology makes possible the rapid processing of the copious amounts of data collected by IoT sensors.

Because of close relationships, electronic and mechanical proximities within a design are often necessary for optimum operation, with minimal signal losses and phase shifts, by minimizing the electrical lengths of cables and other interconnections. What follows are closer looks at four key emerging technology areas and some examples of how these wireless-fueled technologies are being used in beneficial applications. ■

Artificial Intelligence and Machine Learning Bring Smarts to RF Systems

Learn how AI and ML will help detect, classify, and identify RF signals in an increasingly crowded EM spectrum.

COMMUNICATIONS AND OTHER high-frequency electronic systems are becoming more complex with each channel of voice and data they carry. As the content of communications systems increases, companion technologies such as [artificial intelligence \(AI\) and machine learning \(ML\)](#) enable machines to help human users more rapidly handle growing amounts of information with minimal delays or loss of data.

As the volume of data continues to escalate, AI and ML will become more integrated into electronic devices to help sort through massive amounts of information in many industries, from automotive and medical through military and telecommunications applications.

For all of the users they help, from consumers through classified surveillance professionals, AI and ML technologies are constantly considered for integration in wireless system and equipment designs. This is because RF/microwave signals continue to crowd available electromagnetic (EM) frequency spectrum.

As [cellular communications towers rise through the Fifth Generation \(5G\) of wireless communications networks](#), growing numbers of EM signals must be sorted for each application and propagation distance, including Bluetooth, cellular, and Wi-Fi signals. High-frequency filters provide effective sorting of signals at sufficiently high received amplitudes, but with tradeoffs in insertion loss, delay time, and other signal characteristics. Microprocessors and other integrated circuits (ICs) equipped with AI and ML capabilities achieve signal sorting with no loss of signal power and minimal delays.

With AI and ML, a growing number of wireless signals can be detected, classified,

identified, and received/transmitted with low latency and high efficiency.

AI/ML's Role in Detecting, Classifying, and Identifying RF Signals

Algorithms developed for AI/ML applications can serve high-frequency signals for beyond line-of-sight (LOS) use. In physically crowded urban environments, for example, AI and ML can sort through multiple received signals to correct multipath effects. If applied to low-probability-of-intercept waveforms, such algorithms must support wide dynamic ranges and low signal-to-noise ratios (SNRs). Any latency in signal processing must be minimized for effective use of AI in high-frequency receivers.

For instance, AI algorithms can assist surveillance receivers by detecting, separating, and identifying radar signals in dense EM environments. As EM energy sources increase for any environment, AI/ML algorithms for detecting and classifying RF/microwave signals must apply to ever-wider frequency bandwidths.

ML methods have been found useful for counter-jamming protection in communications, radar, and electronic-warfare (EW) systems by detecting and analyzing anomalies and unusual EM patterns in an operating environment. Countering a jammer requires detecting its energy and instantly adapting to its presence in the environment. The solution may need changes to transmitted and received waveforms or even a shift to another part of the available frequency spectrum.

Implementing an automatic counter-jamming operating mode within a radar system requires extreme signal-generation agility and flexible reception capabilities, such as from an arbitrary waveform gener-



1. The model BOA3 smart camera employs AI and ML to enhance industrial parts inspection. Teledyne Vision Systems

ator (AWG). It also requires a broadband receiver to detect unknown signals within a wide expanse of frequency spectrum—signals that are frequency-hopped across the spectrum.

The receiver may also benefit from the flexibility afforded by a [software-defined-radio \(SDR\)](#) architecture. SDRs capable of detecting unknown signals employ AI-based signal processing to sort through copious amounts of captured signal data, and they provide the performance and agility required by modern signal-intelligence (SIGINT) systems.

Solutions brought on by integrating AI and ML technologies into a communications or radar system require additional supporting RF/microwave technologies if not already contained within the system. But the application of AI and ML equipment with deep-learning (DL) measurement approaches makes it possible to sort through enormous amounts of data from counter-jamming systems to develop solutions within hours and a fraction of the time required by other computer-based search algorithms.

Artificial Intelligence and Machine Learning Improve Antenna Arrays

Integration of AI, ML, and DL technologies into electronic products with RF/

microwave capabilities is boosting performance across a wide range of applications and across many market areas. The technologies provide control of array antennas, including those using microelectromechanical-systems (MEMS) techniques to achieve EM antenna patterns from physically small devices.

With increasing demand for antennas for Global Positioning System (GPS), mmWave, unmanned aerial vehicle (UAV), and satellite communications (satcom) applications, AI will accelerate the modeling of essential requirements into antennas with increased coverage and spectrum efficiency.

For EW, [Honeywell](#) recently earned a \$16 million contract from the [U.S. Navy](#) for 25 antenna-array panels for the [Surface Electronic Warfare Improvement Program \(SEWIP\) Block 2](#). The latest version of the shipboard combat system uses the antenna arrays and EW receivers to detect and analyze potential threats from anti-ship missiles.

AI-Powered Components Feed ADAS Systems Better Data

Demand for AI/ML technologies is fueled by growing mobile electronics applications, such as cellular telephones and military portable radios. Applying AI/ML algorithms and switching capabilities to protective circuitry for batteries in mobile devices promotes efficient use of battery power and increases a portable device's mobile operating time.

Even suppliers of essential passive components, such as [Kyocera AVX](#) with smart capacitors, are exploring the use of AI and ML in power supplies that can greatly extend a mobile radio's operating time per charge. [Kyocera AVX](#) recently introduced power components employing AI/ML techniques at [electronica 2024](#) ([see our coverage here](#)), serving applications such as automated driver-assistance systems (ADAS), battery-management systems (BMS), and tire-pressure monitoring systems (TPMS).

Automotive electronic systems like ADAS rely heavily on AI/ML process-



2. ADAS-equipped vehicles rely on AI and ML technologies to enhance driver safety. *Continental Automotive*

ing and on ultrawideband (UWB) active and passive RF/microwave components to handle 76- to 81-GHz millimeter-wave signals for multiple collision-avoidance radar systems per vehicle. While UWB components from suppliers such as [NXP Semiconductors](#) and [Texas Instruments](#) help transfer high-frequency signals within ADAS environments, AI/ML technology helps automotive radar systems detect smaller objects and quickly identify them even in cluttered spaces.

AI's Role in Designing and Operating MIMO Antenna Arrays

Using AI, directional beamforming with multiple-input, multiple-output (MIMO) antennas can be performed effectively and efficiently even at small-wavelength, millimeter-wave frequencies. [MathWorks](#) provides modeling software for designing MIMO, phased-array, and other complex antennas, while [MMWAVE Test Solutions](#) offers three-dimensional (3D) positioners for antenna testing. Also, [Keysight Technologies](#) supplies a comprehensive guide on testing phased-array antennas.

Antennas steered by AI are being developed for a host of applications, including for inspection and testing. [Olympus Inspection Systems](#) from Evident employ phased-array antennas under AI control to provide material and product inspections with extreme precision even at the high speeds meant to boost manufacturing efficiency.

Optical inspection systems based on cameras are also getting upgrades with

the addition of AI/ML technology like [Teledyne Vision Solutions' model BOA3 smart camera](#). Designed for industrial inspection applications ([Fig. 1](#)), the device provides resolution of 1.2 to 12.0 Mpixels in monochrome and color versions. It leverages AI-based computer vision to aid with positioning and part location.

System-level suppliers such as [Continental Automotive](#) provide a wide range of ADAS radar solutions to boost vehicular safety ([Fig. 2](#)). Use of AI and ML within ADAS vehicles enables analysis of data from multiple sensors, e.g., cameras, radars, and light detection and ranging (LiDAR) systems, and supports special safety features like emergency braking. Moreover, it enables self-driving vehicles to make real-time decisions concerning road situations.

As applications for radar and other high-frequency electronic systems reach beyond traditional military and newer automotive settings, those radar systems will be less conspicuous in use and well accepted for the processing power provided by AI and ML technologies.

A passive Wi-Fi radar constructed with multichannel SDR devices from [National Instruments](#) has been used in medical and hospital applications, although the system is undetectable and well-suited for military use. For developers of smart signal-detection systems, the [OmniSIG software development kit](#) from [DeepSig](#) uses DL techniques to train signal-detection sensors on how to read certain types of signals. ■

Cognitive Radios Deftly Park Signals

With assistance from AI technology, cognitive radio systems will find space for signals in an increasingly crowded spectrum environment.

BANDWIDTH FOR COMMUNICATIONS

and other wireless applications is limited and being rapidly consumed by emerging applications. National organizations such as the [Federal Communications Commission](#) (FCC) closely monitor frequency spectrum within the electromagnetic range in attempts to minimize interference or problems from overlapping EM signals. But when frequency spectrum appears filled, innovative technologies like cognitive radio (CR) can provide the means to employ spectrum that's otherwise unoccupied.

In a CR system, a transceiver detects when communications channels are being used or not. It instantly switches to unoccupied frequency spectrum while avoiding occupied channels. By moving to otherwise unused spectrum and eschewing occupied frequency ranges, CR systems feature increased spectrum efficiency compared to traditional wireless systems, with high quality of service (QoS) for its users.

In addition to the FCC helping to monitor commercial or non-federal radio users of EM bandwidth, the [National Telecommunications and Information Administration](#) (NTIA) checks on the radio use of frequency spectrum by government users, such as military troops. These bands aren't utilized with equal efficiencies since some bands, e.g., cellular radio bands, are overcrowded. Others, such as military radio bands, are often rarely used.

But as the number of wireless devices, including at higher frequencies, continues to climb, EM spectrum must be

used intelligently. CR systems provide the means of filling otherwise unused frequency spectrum.

Cognitive Radio Melds Spread-Spectrum, Frequency-Hopping, and AI Technologies

CR systems combine several communications techniques, such as spread-spectrum radios and frequency-hopping radios, guided by artificial-intelligence technology to make efficient use of otherwise unoccupied frequency bandwidth.

A CR system operates within two switchable networks: a primary network and a secondary network. The primary network is a communication system's licensed frequency band, while its secondary network is typically frequency spectrum unused by that CR system except when the licensed spectrum is occupied. A CR system features cognition and capabilities for reconfiguration and learning:

- Through cognition, the radio understands its geographical and operating environments.
- Through reconfiguration, the radio can autonomously and dynamically adjust for optimum operation under changing conditions.
- Through learning, a CR system can adapt to new situations.

To detect radio activity within a frequency range, a CR system performs spectrum sensing to identify licensed users. Spectrum sensing can also detect when holes exist within a defined frequency range, and a CR can make use of those frequency holes without a license. Spectrum sensing may be conducted cooperatively, in which spectrum information is shared among multiple CR devices, or non-cooperatively, in which each CR device acts on its own.

To further understand how available frequency spectrum is occupied, CRs check on the availability of the frequency spectrum according to a database main-

tained by the FCC. While this information, such as that used by commercial broadcast stations, is highly accurate, it may not be updated in a timely fashion. Thus, CRs may not always know of all available frequency spectrum.

Several types of CRs contribute to radio access networks (RANs), including heterogenous and spectrum-sharing CRs. Heterogeneous CRs operate via a network-centric approach, with multiple RANs having the same or different protocols and multiple fixed-frequency bands allocated to the RANs.

In spectrum-sharing CR systems, multiple RANs share the same frequency band, and they're tightly controlled for optimal use of available frequency bands. Heterogenous and spectrum-sharing CRs attempt to make optimum use of available bandwidth. CRs can also be categorized as full-cognitive or spectrum-sensing designs—the former uses as many CR sorting mechanisms as possible, while the latter works around established channels (such as television broadcast stations) in the frequency spectrum.

Finding Frequencies Using A/D-D/A Conversion and Spectrum Hopping

By enhancing software-defined radios (SDRs) with AI technology, CR developers can design dynamically tunable radio systems in compact housings. In an SDR, most radio parameters are adjustable by means of software control of the radio's digital hardware. Received high-frequency analog signals are transformed into the digital realm by high-speed, high-resolution analog-to-digital converters (ADCs) and from digital back to the analog realm by high-speed digital-to-analog converters (DACs) for transmission.

High-speed microprocessors and field-programmable gate arrays (FPGAs) lend the processing power for programming an SDR's center frequency and bandwidth, as well as parameters like frequency-hopping patterns and speeds. Not all designs are in

the microwave range, as [Thales](#) recently announced its use of CR technology for a line of high-frequency (HF) radios capable of automatically switching frequency channels when dealing with jammers.

The Ettus Research model B210 Universal Software Radio (USRP) from the [Ettus Research](#) brand of [National Instruments](#) has become something of a reference design for SDR-based CRs. The MIMO radio operates over a continuous frequency range of 70 MHz to 6 GHz in a compact enclosure (*Fig. 1*). And the model RB210 SDR from [Pixius Technologies](#) is designed to fit into a ruggedized, weather-proof package measuring just 87 × 156 × 300 mm and weighing less than 7 lbs., with options for full military-grade versions.

The versions of the B210 and RB210 SDR/CR units leverage the model AD9361 direct-conversion transceiver IC from [Analog Devices](#) for as much as 56 MHz of real-time bandwidth across the wide frequency range. The wideband SDR/CR with its two receive and two transmit channels is a fit for many applications, including advanced wireless, radar, and SIGINT systems in airborne and ground vehicles, as well as shipboard and soldier-mounted platforms.

Single PCB for Experimenting with Cognitive Radio

For experimenters, [Digilent](#) offers its USRP B200 SDR/CR (*Fig. 2*) with one

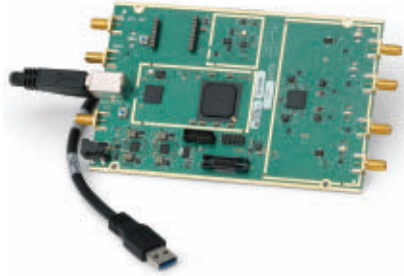

1. Model B210 is a four-channel MIMO SDR/CR with a continuous frequency range of 70 MHz to 6 GHz in a compact enclosure. *Ettus Research | NI*

receive and one transmit channel on a single printed-circuit board (PCB). It provides continuous frequency coverage from 70 MHz to 6 GHz with as much as 56 MHz of instantaneous bandwidth. It also features a Universal Serial Bus (USB) SuperSpeed interface and 12-bit ADCs and DACs. This PCB version of the SDR/CR measures 9.7 × 15.5 × 1.5 cm and weighs just 350 g. It's powered by a standard USB 3.0 connection and an accessory kit is available for assembling a compact enclosure.

For those in need of two receive and two transmit channels on a PCB, the company's model USRP B210 is a four-channel version with a +6-V DC power supply. Because its processing power extends across two additional channels, the instantaneous bandwidth per channel drops to 30.72 MHz for each of



2. Model USRP B200 is an SDR/CR with one receive and one transmit channel on a single PCB powered by USB connection. *Digilent*

the four channels across the same frequency range. The four-channel SDR/CR provides fully coherent 2 × 2 MIMO capability with full- or half-duplex communications channels.

While CR technology has room for growth, especially at higher signal frequencies where more spectrum is available, its innovative use of digital technology clears the way for the intelligent radios needed for many markets, especially medical applications.

Numerous medical facilities have explored the use of SDRs for monitoring patients with serious health issues without any interruptions in the communications links. Fueled by AI and ML technologies, SDR/CR equipment can provide continuous coverage with the intelligence to alert medical professionals according to critical signs and symptoms. ■

IoT Sensors Add Connected Security

Thanks to agencies like the DoD leading the way, IoT/IIoT cybersecurity is top of mind for network admins in 2025 and beyond.

SENSORS WITH INTERNET of Things (IoT) technology deliver an extended view of the world. They provide instant status updates for many electronic systems, from battery charge levels to operating temperature. With internet connectivity, IoT sensors reach well beyond any one environment and provide almost unlimited information on an application of interest.

However, when transferring so much information, they must do it securely. Equipping IoT devices with suitable cybersecurity is as essential as the information collected by those devices. As more devices come online, connected to the internet, the IoT attack surface grows larger and more vulnerable to cyberthreats.

IoT devices are commonly used in “smart” homes and offices as part of automated environments, such as for turning lights on and off and setting temperatures. They're increasingly being employed in offices and vehicles as electronic door locks, to enable access by means of codes transmitted on a mobile telephone.

These devices have been widely accepted in manufacturing and production settings, as industrial Internet of Things (IIoT) devices, helping to automate factories and boost product manufacturing speeds and repeatability. When IoT devices are used to control physical equipment, such as production or inspection equipment on a factory floor, they're referred to as operational technology (OT) devices.

Because IoT devices share information by means of the internet and communicate via wireless standards, such as Wi-Fi, they can be accessed by non-users. They're typically designed to convert real-world situations into analog and digital signals for analysis, but without blocking those signals from access by non-users. Cybercriminals hoping to benefit from an IoT device's collected data can readily access the data, often without countermeasures or even detection from the IoT device.

Interconnected IoT devices have become part of many automated electronic systems. Thus, a cybercriminal can not only steal information from many IoT devices, but they're also able to degrade the efficiency of an IoT-connected automated factory.

IoT attacks can occur in many ways, including as a denial-of-service (DoS) attack. In severe cases, such as for IoT devices in healthcare or warfare applications, cybercriminal interference could be fatal. IoT security depends on the development of effective security systems capable of providing such functions as IoT device authentication and encryption to ensure the safety and security of data within IoT-powered systems.

U.S. DoD Proactive in Establishing Cybersecurity

The [U.S. Department of Defense](#) (DoD) is aware of the value of cybersecurity for IoT devices, throughout their application and market areas. In early 2023, it published its [Cyber Workforce Strategy](#) with their intended goals, plus released plans for implanting that strategy later that year as its "Cyber Workforce Strategy Implementation Plan."

One of those goals was to reduce the "time to hire" for civilian cybersecurity workers to about 73 days. The average time to hire civilians working in cybersecurity for the DoD had been about 79 days. By adding staff more quickly, vacancies in the DoD cyber workforce have been significantly reduced. In 2024, the DoD established its [Cyber Academic Engagement Office](#) to help coordinate cyber-related activities between the DoD and academia.

The DoD's [cybersecurity maturity model certification](#) (CMMC) program works with private sector companies seeking to comply with cybersecurity requirements before they can bid on defense contracts. Private companies must demonstrate the security of their computer networks, including connected IoT devices. Also, cybersecurity practices provide adequate defense against cyberthreats as well as adversaries trying to gain information about government contracts and weapons systems design and development.

The latest CMMC rule simplifies the process of the DoD working with industry on cybersecurity, reducing assessment levels for approval from five to three by eliminating two transition levels. For cybersecurity with the DoD, private companies must comply with cybersecurity requirements established by the [Federal Acquisition Regulation](#) (FAR) office and the [National Institute of Standards and Technology](#) (NIST). When evaluating the cybersecurity of IoT devices, NIST tries to maintain a technology-agnostic approach whenever possible.

IoT Device Cybersecurity Leans on Security Devices and Authentication

While IoT devices aren't typically equipped with cybersecurity by their manufacturers, the addition of security devices to IoT-equipped networks can provide data protection from cybercriminals.

IoT network security solutions rely on effective data and network management, such as end-to-end encryption of transmitted and stored data, secure communications within the network, segmenting

and partitioning a network according to the placement and data processing of IoT devices, and proper device authentication approaches on an IoT-equipped network. Network monitoring with the aid of intrusion detection systems (IDS) can help identify cyberattacks and shift data-protection resources as needed for protection against those attackers.

IoT-equipped networks can be made less vulnerable to attacks from cybercriminals by adding special protective devices such as security enhancement tools from [CrowdStrike](#). As with the firm's Falcon for IT platform, with more than 10 different security and AI-driven information technology (IT) tools integrated into a single platform, [Falcon Discover for IoT](#) was developed to add security to a company's networking capabilities by enhancing the visibility of IoT devices on the networks.

The platform eliminates blind spots that can leave a network and its IoT devices vulnerable to cyberattacks. It helps secure a company's industrial control system (ICS) and the assets contained within its IT and OT functions.

In contrast, the [ReliaGATE 15A-14](#) from [Eurotech](#) is a cybersecurity-certified modular gateway that increases the security of IoT devices for a wide range of applications. It's designed to simplify the compliance of various kinds of IoT devices with regional and carrier certifications and help speed the installation of IoT projects.

The gateway was developed to speed and simplify IoT projects due to its pre-certification to key IoT requirements, such



The ReliaGATE 15A-14 modular gateway helps increase the security of IoT devices for a wide range of applications. Eurotech

as ISA/IEC 62443-4-2, and help IoT users meet current security regulations for IoT devices, including those detailed in the U.S. IoT Cybersecurity Improvement Act, the European Union (EU) NIS2, and the Cyber Resilience Act. The gateway (*see figure*) provides a straightforward programming environment and helps create secure connections of IoT-driven networks with services and functions on “the cloud.”

Next-Generation Firewalls Reduce Cyberthreats

The **FortiGate 7000F** series of next-generation firewalls (NGFWs) from **Fortinet**

helps organizations build secure networks. IoT devices can use NGFWs such as the FG-7081F firewall with processing speeds to 405 Gb/s and the FG-712F firewall with processing rates to 675 Gb/s. The company’s firewalls automatically control, verify, and facilitate user access to network applications, so that cyberthreats are reduced by providing access only to validated users.

For system designers seeking to strengthen IoT security, the **SensorTile. box PRO** from **STMicroelectronics** is a wireless development kit that enhances IoT cybersecurity by using remote sensor data combined with local

processing. It employs the firm’s model **STM32U5 microcontroller** connected to the **BlueNRG 5.2** Bluetooth wireless network coprocessor system-on-chip (SoC) device with a full set of motion and environmental sensors.

Growing numbers of IoT devices will result in massive amounts of data that must be channeled and stored. Because security can’t be practically implemented in every IoT device, demand will continue to grow for firewalls and other security devices that make IoT devices realistic solutions for connection and communication via the internet. ■

Open RAN Extends Wireless Radio Reach

O-RAN technology stands poised to increase interoperability between equipment from disparate vendors even as it promotes lower latency, lower equipment costs, and higher system performance.

RADIO TECHNOLOGIES CONTINUE to evolve and add diverse radio formats to an ever-crowded operating environment. Although many frequencies and radio configurations may be incompatible, the **open radio-access network** (O-RAN) is an attempt to enable the **U.S. Department of Defense** (DoD) and other users to mix and match components and radio systems from different suppliers to enable a wide range of radio hardware and software to be interoperable.

By establishing an O-RAN ecosystem, the use of emerging technologies such as artificial intelligence (AI) and machine learning (ML) can provide increased efficiency and flexibility to modern radio systems. It will also support communications across commercial and military systems, including 5G cellular wireless radios.

As cellular wireless technology has evolved, starting with early work by **Motorola** and the development of the Advanced Mobile Phone System (AMPS) by **Bell Laboratories**, it has extended from 3G and 4G to the current 5G. Maintaining compatibility among hardware and software in any one generation is a chore,

let alone among multiple generations in use at the same time.

Early RANs have developed into a central RAN (C-RAN) architecture capable of taking more equipment and software into service. There’s dedicated support for in-building wireless communications and high-speed, low-loss, fiber-optic links.

O-RAN Cuts Cost Without Performance Degradation

O-RAN extends the range of usable hardware and software further, promoting lower latency, lower equipment costs,

and higher system performance. O-RANs enable carriers to use cost-effectively disparate components with just minimal tradeoffs in performance.

Development of O-RAN specifications for compatibility of hardware and software includes secure access and control of data to minimize network cybersecurity concerns. Aided by O-RAN methods, integration of indoor and outdoor cellular networks will be simplified and less expensive for installers and network operators.

5G incorporates equipment from many earlier wireless cellular generations and



The Cisco Nexus 93180YC-FX3 supports bandwidths to 3.6 Tb/s for O-RAN systems from a single rack-mount unit. Cisco

many cell configurations, such as small and large cells and indoor and outdoor cells at different frequencies. Thus, requirements for **5G O-RAN** can define neutral hosting of multiple wireless cellular access types, including distributed-antenna-system (DAS) cells, small cells, and macro cells.

The O-RAN architecture is being developed by the **O-RAN Alliance**, a worldwide association of mobile network operators, manufacturers, designers, and researchers working to redefine RAN methodologies for O-RAN and 5G.

One goal for the group is to support the development of hardware and software that will operate seamlessly and securely in a 5G wireless cellular network and beyond, to 6G wireless cellular networks. Some commonality exists for 5G network components: antennas and radio-unit (RU) software are usually from the same manufacturer, while the distribution unit (DU) and centralized unit (CU) may be from another company.

Communication and Synchronization Among Network Functions

By breaking the O-RAN into multiple network functions, such as a RU, DU, and CU, those functions can be clearly defined for development by multiple vendors. Communication among the network segments is essential for reliable operation and requires well-defined communications interfaces, with requirements and specifications available to multiple vendors for development on an open computing platform or open cloud.

To maintain timing and synchronization among the multiple network segments, the O-RAN Alliance sets exacting time and frequency synchronization standards for O-RAN 5G equipment vendors. To better understand the special test requirements for O-RAN equipment and systems, **Keysight Technologies** offers a comprehensive eBook on its website.

Building upon a \$14 billion, five-year O-RAN agreement with AT&T in 2023, **Ericsson** recently signed a 5G upgrade contract with MasOrange, Spain's largest telecommunications operator, to upgrade

its network with O-RAN technologies. MasOrange was formed by the merger of the Spanish part of France's Orange company and the telecommunications company MasMovil. It's one example of the wireless telecommunications industry embracing O-RAN technology as it hopes to improve performance and value as the number of wireless cellular customers ramps up.

Cisco, one of the pioneers in O-RAN technology for wireless cellular networks as part of the O-RAN Alliance, has developed computing and switching equipment to assist with multivendor equipment interoperability in cellular networks. The company's Nexus 9000 Series switches provide the hardware and software support capabilities aided by AI and ML technologies to enable O-RAN operation with minimal latency and congestion.

These compact switches provide high performance with excellent power efficiency and can be adapted for high cybersecurity visibility in the most critical security situations. For example, the Cisco Nexus 93180YC-FX3 fits into a single rack-mount unit (*see figure*) that supports 3.6-Tb/s bandwidth. It provides 48 downlink ports at switching speeds to 25 Gb/s, and uplink ports can be configured as 40- or 100-Gb/s Ethernet channels.

Optical telecommunication equipment developers such as **Corning Optical Communications** are also contributing to the progress of 5G O-RAN technology by providing the high-speed, wide-bandwidth links for transferring data, video, and voice within buildings and wireless base stations.

The firm's success in achieving optimal 5G O-RAN solutions involves a balanced approach to employing 5G O-RAN gear with existing systems, such as C-RAN equipment. Its expectation is that O-RAN will provide the basis for 6G cellular wireless networks and beyond.

U.S. DoD Evaluating O-RAN for Command and Control

While O-RAN makes the interaction of many different components and systems

possible for 5G and beyond, it's not just for civilians. The U.S. Department of Defense (DoD) recently contracted **Hughes Network Systems LLC**, a subsidiary of 5G innovator EchoStar, for \$6,514,697.51 to develop an O-RAN prototype at Fort Bliss, Texas.

The prototype equipment will be used in a temporary network for evaluation and then serve as part of Hughes' commercial wireless network supporting the DoD and commercial customers around Fort Bliss. The project will offer the U.S. Army and DoD the opportunity to explore the real-time command and control capabilities of an O-RAN system, and for the Army to size up O-RAN as a component for the Army Unified Network.

To keep pace, the U.S. Navy recently contacted **BAE Systems** concerning the use of O-RAN technology in its Network Technical Common Data Link (NTCDL) systems. These systems enable simultaneous transmission and reception of real-time intelligence, surveillance, and reconnaissance (ISR) data.

Within the U.S. government, **NIST** is conducting research on O-RAN with the intent on developing effective networking strategies for optimizing multi-vendor devices. The strategies must ensure the highest security while promoting interoperability in collaboration with the O-RAN community.

NIST researchers are applying ML algorithms to simulate a wide range of operating conditions that must be handled by O-RAN systems. The experimentation is meant to aid both commercial and government stakeholders, using NIST's O-RAN testbeds to evaluate different setups.

In mid-2024, in collaboration with NIST's National Cybersecurity Center of Excellence, the organization's Wireless Networks Division hosted an interim meeting of the O-RAN Alliance's Security Working Group. These attendees brought concerns about the cybersecurity of O-RAN systems. While focused on 5G, consideration was given to emerging 6G designs and how AI and ML could be applied for heightened O-RAN security. ■

The Intelligent Future of Spectrum Visibility (Part 2)

Take a tour through the paradigm shift brought forth by cognitive radar and AI's integral role in electromagnetic dominance.

by **Alejandro Buritica**, Product Manager, RF & Wireless, Tektronix

IN PART 1 of this two-part series, we covered the current challenges that confront spectrum operations in an evolving electromagnetic landscape. We also discussed the transformative role of test and measurement tools.

Here in Part 2, we highlight the paradigm shift brought forth by **cognitive radar** and AI's integral role in electromagnetic dominance, signifying a leap to more sophisticated and efficient spectrum management. Through examples of real-world applications, the discussion touches on the practical implications of these advances. It also addresses the inherent technical challenges that accompany the course toward a more secure and technologically adept future in the realm of spectrum operations.

The Rise of Cognitive Radar and Cognitive Spectrum Management

Early radar systems, limited as they were by fixed rules, lacked the adaptability required for dynamic threat environments. To empower radar systems to operate more effectively in new environments and situations, researchers began integrating faculties associated with biological cognition, such as perception, thinking, judging, problem-solving, and remembering, into radar systems.

One might compare a traditional radar system to early versions of automotive cruise control, which maintain a constant speed but can't adapt to changing traffic conditions or obstacles on its own.

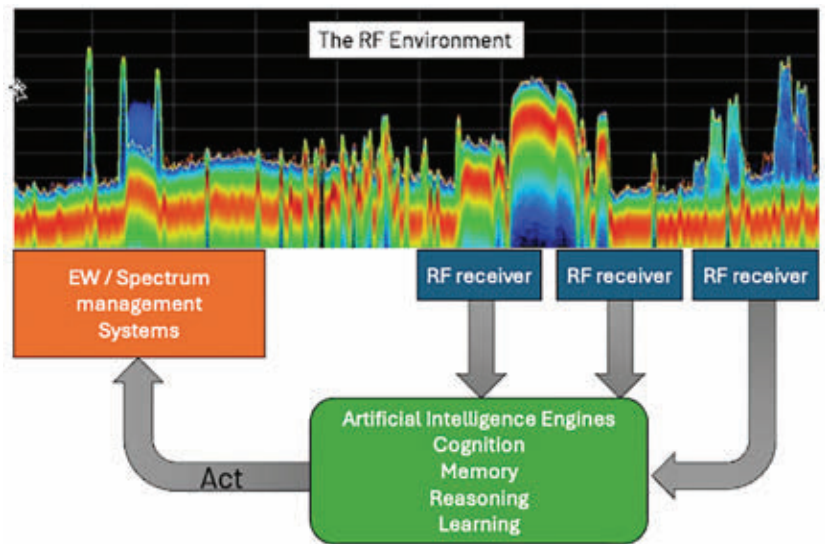

1. Cognitive spectrum management (CSM) uses advanced algorithms to continuously analyze patterns in spectrum usage and predict future spectrum usage based on historical and real-time data. Images courtesy of Tektronix

In contrast, cognitive radar aims to operate like a fully autonomous self-driving car equipped with AI. Such intelligent vehicles don't simply maintain speed. Rather, they sense and understand their environment; make decisions based on real-time data regarding traffic, road conditions, and unexpected obstacles; and adapt their driving accordingly.

Similarly, cognitive radar continuously scans its environment, intelligently adjusting its operating parameters in response to changing conditions, and then makes autonomous decisions about how to best detect and track targets in rapidly changing and adversarial environments.

Cognitive spectrum management (CSM) represents a revolutionary shift

from traditional, static spectrum management to a dynamic, intelligent system that leverages AI and machine learning. At its core, CSM uses advanced algorithms to continuously analyze patterns in spectrum usage and predict future spectrum usage based on historical and real-time data (Fig. 1).

RF instruments play a vital role in the creation and deployment of cognitive radar and CSM as extremely sensitive acquisition engines and computing nodes that can sample, process, record, and share vast amounts of spectrum data. This data feeds into AI algorithms that learn and evolve, constantly improving the system's ability to manage the spectrum. The following are among the most popular and

promising types of algorithms for cognitive RF systems:

Neural Networks and Deep Learning in Cognitive RF Systems

These algorithms are particularly effective in recognizing complex patterns in spectrum usage. Based on large training sets with diverse types of signals from known electromagnetic environments, they can map a set of inputs to a set of desired outputs.

For instance, a deep neural network (Fig. 2) can be trained to take in various types of signals received over the air (inputs) in a crowded spectrum environment. Then it can classify those signals into communication signals, radar pulses,

unmanned-aircraft-system (UAS) control channels, interference, licensed or unlicensed broadcasts, and other types of categories (outputs).

Reinforcement Learning in Cognitive RF Systems

In contrast to neural networks, reinforcement-learning (RL) algorithms learn not by identifying patterns from training sets, but by perceiving the state of the environment and interacting with it (Fig. 3).

In RL, the goal is for the algorithm (the “agent”) to learn a specific task or set of behaviors, like how the police trains K9 dogs to sniff out explosive substances. The RL agent learns through trial and error, exploring different actions and observ-

ing the outcomes, as the K9 would try various approaches to understand what the trainer wants it to do. The trainer gives positive outcomes (or “rewards”) to the agent when it performs the right action and negative outcomes, or lack of a reward, for the wrong actions.

In the case of spectrum operations, an autonomous radio transmitter system might be rewarded for increasing the signal-to-noise ratio of its output until it starts to affect neighboring channels, changing the state of the environment, and failing to get rewards. Through experimentation, feedback, and gradual adaptation, RL agents improve their performance and learn the desired behavior or task.

The goal of this machine-learning technique is to learn a policy. Eventually, the RL agent becomes proficient in the task, consistently making choices that yield the highest rewards depending on the state of the engagement, having learned the optimal “policy” based on the state of the engagement.

To illustrate this point in radio operations, consider RL algorithms continuously sensing the environment, and then managing and adapting the frequency allocation of communication networks to avoid interference and jamming.

By receiving quantitative and qualitative feedback on current conditions and the effectiveness of each frequency choice (such as received signal strength, signal clarity, and resistance to jamming), the RL system learns to select the optimal frequencies under varying conditions. Over time, it becomes adept at predicting and avoiding frequencies likely to experience interference, ensuring more reliable communications.

Support Vector Machines in Cognitive RF Systems

Support vector machines (SVMs) are a type of supervised machine-learning algorithm used primarily for classification and regression tasks. They work by finding the decision boundary that best separates different classes of data points. SVMs excel in their ability to handle com-

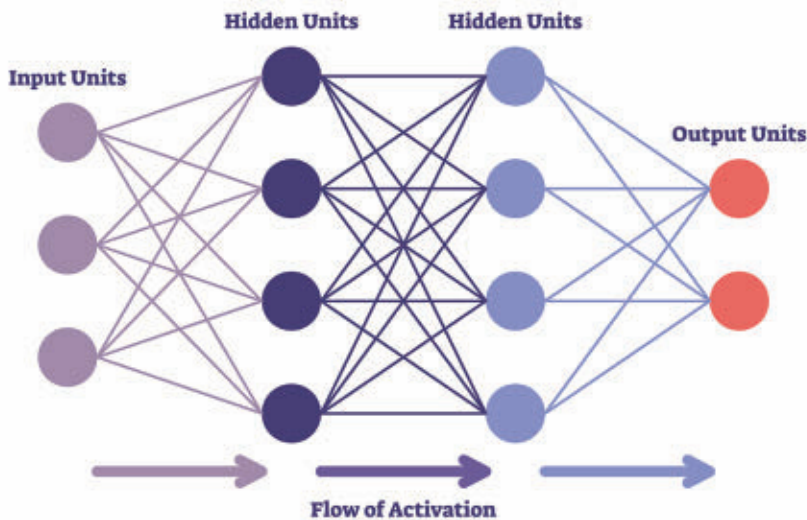

2. Shown is a diagram of a deep neural network for AI/ML applications.



3. This diagram depicts a reinforcement-learning approach with human feedback.

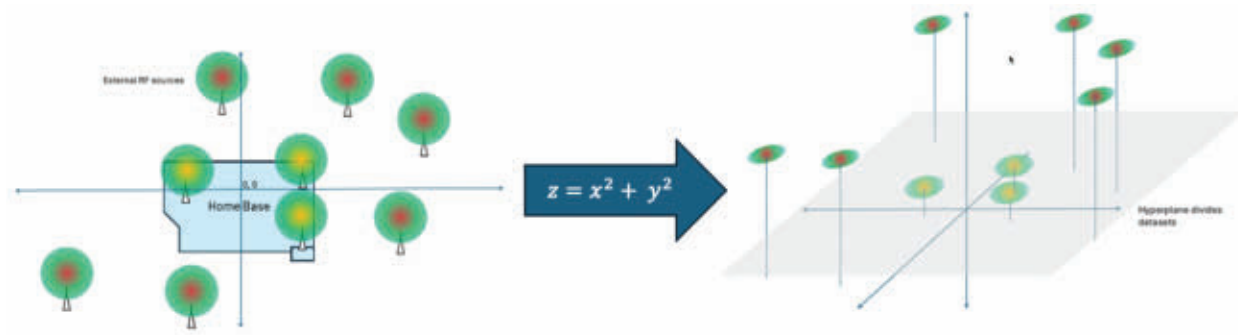

4. This diagram illustrates how an SVM algorithm might apply a decision boundary to distinguish between datasets.

plex classification problems with clear margin of separation.

Spectrum operations systems can use SVMs to distinguish between friendly, hostile, and neutral signals. By training an SVM with examples of various signal types (including their frequency, modulation, and other characteristics), it can learn to accurately identify the nature of new signals it encounters. This is crucial for threat assessment and decision-making in spectrum operations scenarios.

In Figure 4, the spectrum-monitoring system detects and observes various transmitters both outside (red) and inside (yellow) a defined home base perimeter using received signal strength indicators (RSSI), angle of arrival (AoA), signal demodulation, and other characteristics. Here, the SVM algorithm might find a decision boundary between them by squaring their x,y location and using a plane as a decision boundary.

Time-Series Analysis in Cognitive RF Systems

In the context of machine learning and artificial intelligence, [time-series analysis](#) involves examining a sequence of data points collected over time to identify underlying patterns, trends, and correlations.

By analyzing historical data on spectrum usage, machine-learning models can forecast periods of high or low activity. This enables engineers to plan operations during times of lower congestion or prepare for expected increases in communi-

cations or jamming activities when these are most likely to occur.

Similarly, machine-learning models trained on normal spectrum usage patterns can identify anomalies when they occur. This might include unexpected spikes in signal activity or the sudden appearance of unfamiliar signal types, prompting further investigation or immediate countermeasures.

These algorithms anticipate changes and adapt proactively to enhance spectrum efficiency, minimize interference, and improve the security and reliability of spectrum operations.

AI Algorithms on Test and Measurement Instrumentation

Instruments such as arbitrary waveform generators (AWGs), vector signal generators (VSGs), and real-time spectrum analyzers (RSAs) will also benefit from AI algorithms. They will pave the way to developing real-time generation, analysis, and manipulation of high-fidelity, precision signals based on the evolving electromagnetic environment.

AI algorithms can analyze data from one or multiple synchronized RSAs to identify patterns, threats, and opportunities within the spectrum. Such algorithms will also enable AWGs to dynamically generate optimized waveforms that counteract interference, jamming, or spoofing attempts, or to adjust for more efficient spectrum usage.

This synergy facilitates the creation of responsive and adaptive testbeds for

innovative spectrum management and electronic warfare (EW), where systems can learn from past actions, predict future scenarios, and make decisions to optimize performance and effectiveness in real-time.

Technical Challenges in AI Decision-Making

Although the integration of AI-driven systems into electromagnetic-spectrum operations brings transformative advantages, it also introduces a set of challenges that technologists and policy makers need to address carefully.

Acquiring and Managing High-Fidelity Field Data Records

Gathering and processing [high-fidelity field RF data](#) from realistic scenarios poses a significant challenge for researchers and engineers aiming to train cognitive systems. They require rugged RF sensors with superior RF specifications and broad bandwidth to capture and merge data from multiple locations, creating a comprehensive picture of dynamic RF environments (Fig. 5).

To train these systems effectively, teams must meticulously tag, catalog, and load vast datasets covering a broad spectrum of scenarios, frequencies, and environmental conditions. Achieving a comprehensive and representative data collection is a formidable logistical task.

The process of tagging and annotating spectrum data demands intensive labor, as experts must describe the sig-

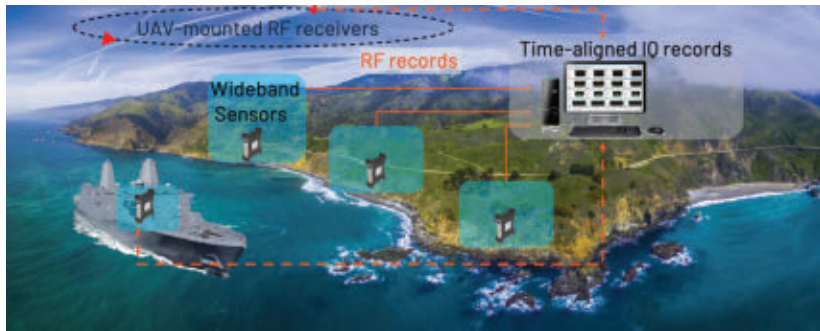

5. In this image, we see how one might capture high-fidelity field RF data from geographically distributed RF sensors.

nal type, source, and environmental context, adding crucial operational or battlefield insights.

Ensuring data labeling is consistent and accurate across extensive datasets is critical to train AI models properly, as discrepancies can degrade model performance. Moreover, preprocessing the data—normalizing, reducing noise, and extracting features—can add hours of work.

Computational Requirements for Cognitive RF Systems and AI Algorithms

Running cognitive spectrum-management algorithms, especially those employing advanced machine-learning techniques like deep neural networks, require clusters of high-end processors capable of performing trillions of floating-point operations per second (TFLOPS).

To put this into perspective, a cognitive spectrum-management system deployed in a military operation might require a computing setup that rivals or exceeds the capabilities of some of the most advanced commercial servers currently available. This setup would need to be robust enough to handle not only the computational load, but also the challenging environmental conditions often found in military contexts.

However, when it comes to inference—the process of making real-time decisions based on the trained model—the computational requirements decrease, allowing for more manageable field deployments.

Challenges for Test and Measurement Equipment

Instruments like **Tektronix's** rugged RSAs face the challenges of integrating AI capabilities to help engineers understand the electromagnetic environment more clearly as well as develop cognitive spectrum operations systems more rapidly.

AI will enable test and measurement instruments to incorporate expert assistance in knowing how to gather and process high-fidelity field RF data from multiple locations and varied electromagnetic scenarios to produce a comprehensive picture of dynamic RF conditions.

On the generation side, high-bandwidth arbitrary waveform generators will evolve to assist in the dynamic design and creation of waveforms that adapt to RF conditions and measured system behavior.

AI-Driven Spectrum Operations: Staying Ahead with Quality RF Hardware

Mastering intelligent spectrum operations is crucial to staying ahead of swiftly adapting adversaries. Investing in high-quality RF hardware, sophisticated AI algorithms, and robust data-processing capabilities is key to unlocking new potentials in EW and communication.

The success of AI-driven spectrum systems depends heavily on the quality of the underlying hardware, including advanced antennas, transceivers, and digital baseband processing units capable of operating across diverse frequencies and conditions. Precision in test and measurement

is essential, delivering RF sensors that capture a broad range of signals to feed accurate, high-quality data into AI models. This synergy between top-notch field data and cutting-edge computing will fuel breakthroughs in spectrum operations.

Reimagining the 1941 Pearl Harbor scenario with AI-powered radar systems illustrates the transformative power of AI. Instead of a tragic surprise, AI's predictive capabilities enable a swift and decisive response, turning a potential day of infamy into a demonstration of the strength of cognitive radar and spectrum operations. Such a scenario underscores the importance of AI in not just responding to threats, but proactively outclassing and outmaneuvering them. ■

REFERENCES

- Del Monte, L.A., *Genius weapons: Artificial intelligence, autonomous weaponry, and the future of warfare*. Prometheus Books, 2018.
- Federal Aviation Administration. (2023). *Drones by the Numbers*. Retrieved January 09, 2024, from <https://www.faa.gov/node/54496>.
- Haigh, K. Z., Andrusenko, J., *Cognitive electronic warfare: An artificial intelligence approach*. Artech House, 2021.
- O. M. Khodayer Al-Dulaimi, M. K. Hassan Al-Dulaimi and A. M. Khodayer Al-Dulaimi, "Cognitive Radio Technologies and Applications in Dynamic Spectrum Access Method," 2022 IEEE 9th International Conference on Problems of Infocommunications, Science and Technology (PIC S&T), Kharkiv, Ukraine, 2022, pp. 9-14, doi: 10.1109/PICST57299.2022.10238684.
- S. You, M. Diao and L. Gao, "Deep Reinforcement Learning for Target Searching in Cognitive Electronic Warfare," in *IEEE Access*, vol. 7, pp. 37432-37447, 2019, doi: 10.1109/ACCESS.2019.2905649.
- U.S. Air Force (2023). Electromagnetic spectrum operations (AFDP 3-85). Retrieved January 12, 2024, from https://www.dctrine.af.mil/Portals/61/documents/AFDP_3-85/AFDP%203-85%20Electromagnetic%20Spectrum%200ps.pdf.
- <https://www.metsci.com/wp-content/uploads/2021/05/Overview-Cognitive-Radar-Past-Present-Future-Gurbuz-et-al-2019.pdf>.
- Statista, "Number of IoT Devices," 2023. Retrieved from <https://www.statista.com/statistics/1183457/iot-connected-devices-worldwide/>.

11 MYTHS

About Machine Learning at the Edge

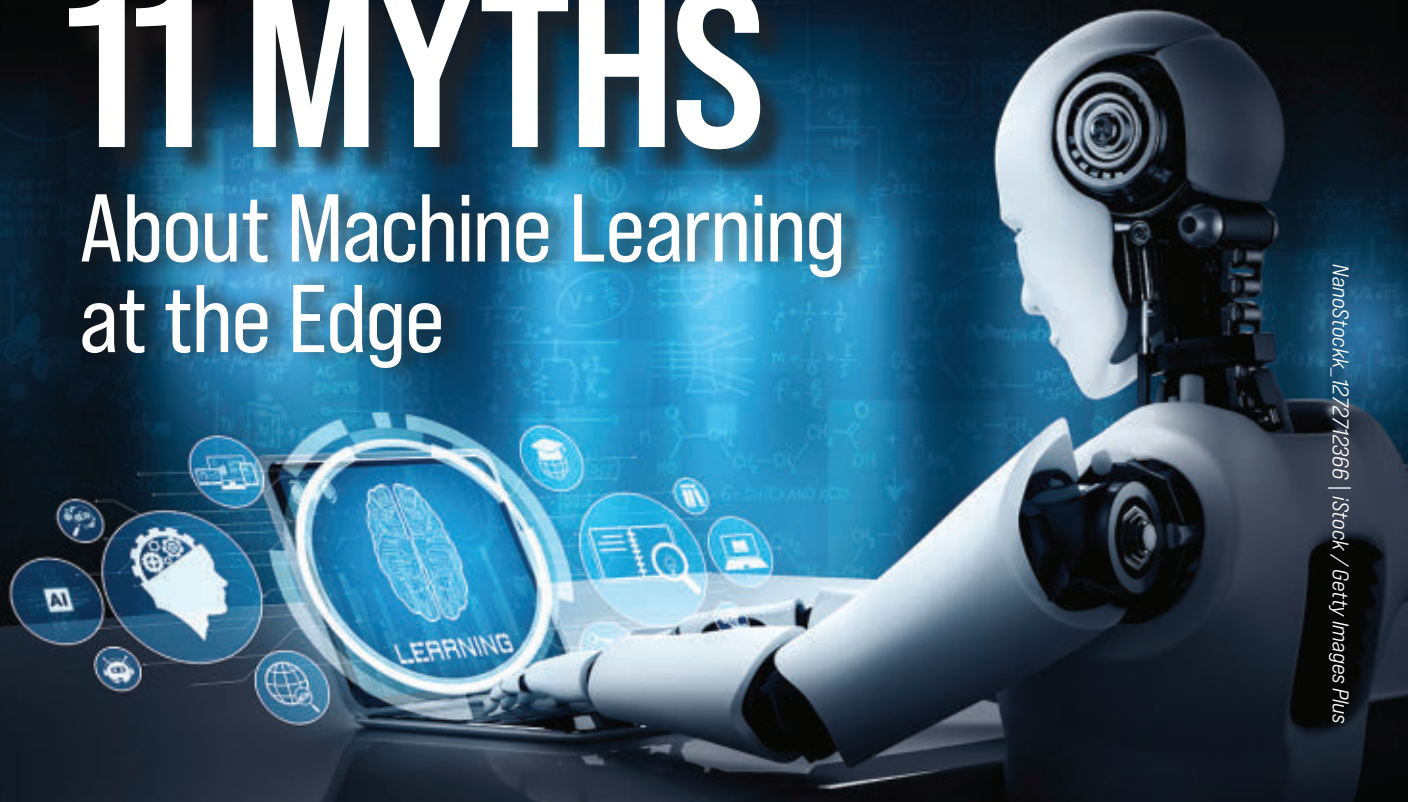

NanoStock_1272712366 | Stock / Getty Images Plus

TDK SensEI's Michael Johnston addresses the myths of applying machine-learning technologies to smart edge devices.

*by Michael Johnston,
Director of Marketing, TDK SensEI*

AS INDUSTRY DRIVES toward digital transformation (DX), one of the key elements that's needed is data to sense what's happening. With the advent of the industrial Internet of Things (IIoT), medical IoT (MIoT), smart homes, smart wearables, and other smart devices, it's all about sensors.

Alongside the sensors, these devices integrate a microcontroller to perform localized **artificial intelligence (AI) at the**

edge to understand the data and provide actionable insights, as well as a battery and connectivity to communicate the sensing data. As this technology ramps up, myths and misconceptions about it also begin to emerge. **TDK SensEI's** Michael Johnston sets the record straight:

1. Edge ML is difficult to develop and requires expensive engineering resources.

In the past, developing **machine-learning (ML)** solutions required expensive engineering resources—domain experts who understand the application and AI experts who design ML algorithms and models that can learn from the data and make actionable predictions or decisions. Today, automated ML applications like AutoML are helping businesses build and scale AI at the edge, enabling those with domain expertise, but not ML expertise, to solve real-world problems quickly and efficiently.

2. Edge ML runs on powerful, expensive hardware.

Edge ML runs models and algorithms on edge devices rather than relying on cloud-based servers. While it's true that powerful and expensive hardware is sometimes necessary for data-intensive tasks such as image recognition, natural language processing, or video processing, tinyML doesn't require expensive hardware to run. In fact, tinyML technologies are already running on low-cost, low-power devices worldwide.

3. Edge ML is only for big businesses.

Edge ML technology is becoming more and more affordable and accessible, and it has relevance and applicability in diverse applications. Indeed, edge ML allows for customization to specific requirements, which is particularly useful for smaller businesses that may have niche needs or want to differentiate their products or services. In particular, industries such

as healthcare, agriculture, retail, smart homes, and environmental monitoring already use edge ML to improve their operations and efficiency.

4. Edge ML is too complex to implement.

While edge ML can indeed involve intricate processes and technologies, it's important to recognize that it has become increasingly user-friendly to implement. With tools like [AutoML by TDK SensEI](#), businesses can create, deploy, and scale edge ML applications quickly and easily.

5. Edge ML is not secure.

Though security concerns do exist in the context of edge ML, they're not insurmountable. The raw data is processed locally at the sensor node and not in the cloud. This means that sensitive operating data is not exposed to the outside world.

Security should be a fundamental consideration from the outset of any edge ML project, and ongoing vigilance is necessary to maintain a high level of protection for data, models, and devices. By following best practices, utilizing secure development methodologies, and staying informed about the latest security threats and solutions, it's possible to design and deploy secure edge ML systems.

6. Edge ML is only suitable for certain industries.

While edge ML can have particularly strong applications in specific industries, its potential extends to a wide range of sectors. Edge ML is valuable for quality control, predictive maintenance, and process optimization in manufacturing. It's able to analyze sensor data from production lines and equipment in real-time to identify defects or anticipate maintenance needs.

In healthcare, [smart wearables](#) and various other medical sensing devices are used for remote patient monitoring, early disease detection, and personalized treatment recommendations. Furthermore, drones and sensors equipped with edge ML capabilities can provide real-time

insights for farmers to help optimize crop management, monitor soil conditions, and identify plant diseases.

7. Edge ML is expensive.

The cost of edge ML solutions is decreasing exponentially. Though there can be upfront costs, it's possible to design edge ML systems that provide a strong return on investment by optimizing development, hardware selection, and operational efficiency.

Today, businesses are able to implement edge ML solutions without breaking the bank. Combined software and hardware solutions mean businesses can quickly create and deploy ML solutions for a variety of use cases without the need for expensive embedded resources and complex deployments.

8. Edge ML is not necessary.

Whether edge ML is necessary depends on the specific requirements and constraints of an application. Not every use case requires edge ML, but it provides valuable benefits in terms of real-time processing, data privacy, offline operation, cost savings, and adaptability. As technology continues to advance, the use of edge ML is likely to expand to address a broader range of scenarios and challenges.

9. Edge ML is too new.

Edge ML is indeed a relatively new paradigm within the field of ML. However, it's far from its infancy. The rapid advances, real-world use cases, and industry support demonstrate its maturity and readiness for practical applications across a wide range of industries, from industrial processing lines to consumer goods like toothbrushes. The technology continues to evolve and is expected to play an increasingly significant role in the future.

10. Edge ML is not mature enough for enterprise use.

Edge ML has indeed reached a level of maturity that suits it for a wide range of enterprise applications. Its ability to process data locally, ensure data privacy, and

provide real-time insights positions it as a valuable tool for businesses looking to optimize operations, enhance decision-making, and gain a competitive edge in their respective industries.

Many hardware and software vendors like TDK offer enterprise-grade edge, industrial ML solutions that are designed to meet the needs of even the most demanding businesses.

11. Edge ML is only for specific applications.

Edge ML versatility allows it to be applied to a broad range of industries and application scenarios, including predictive maintenance, quality control, demand forecasting, fraud detection, and more. The key is to recognize the unique needs and advantages that edge ML can offer and tailor solutions to effectively meet those requirements.

The field of edge ML has witnessed significant growth and maturity in recent years, dispelling various myths associated with its adoption and application. As we navigate the digital transformation era, data and sensors play a pivotal role, making edge ML a key technology for various industries and use cases. We need platforms that effectively democratize AI development, empowering users to gain actionable insights from sensor data more efficiently. ■

The Basics of Radar Technology (Part 2)

Explore radar's development trajectory and how the shift to element-level digital phased arrays is spurring trends that impact component selections.

by **Peter Matthews**, Senior Technical Marketing Manager, Knowles Precision Devices

IN PART 1 of this series, we covered some basic radar functions and design parameters, the factors driving gain in search radar systems, and various approaches to increasing radar performance. Part 2 covers the top trends we're observing as we shift to element-level digital phased arrays and how these trends are impacting component selection.

The Phased-Array Evolution

Radar systems function in defense communication, space exploration, remote sensing, law enforcement, air traffic control, and many other applications where they're operationally critical. With growing demand for multifunctional systems, we're asking more and more of radar technologies.

In the context of defense-related applications, the evolution of **phased-array antennas** has progressed from passive phased arrays to element-level digital phased arrays over the last half-century (Fig. 1). We're already reaping the benefits of the shift.

Many radar systems currently in use are based on previous generations, but today's element-level digital arrays have more flexibility in terms of mode and bandwidth. Further, since each element in the array has its own analog-to-digital converter (ADC), there's an inherent increase in signal-to-noise ratio (SNR). Systems being designed today will make even better use of these benefits.

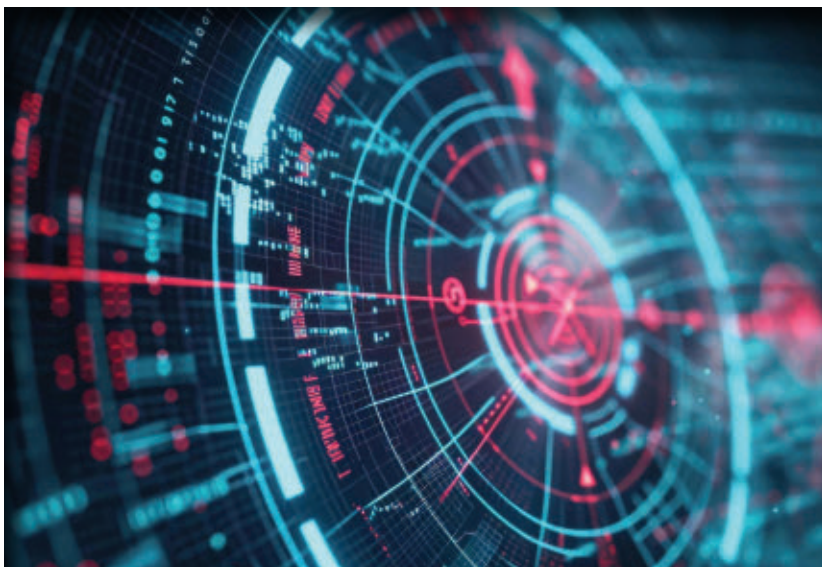

321205236 © Irinaeyomina | Dreamstime.com

The Core Functional Blocks in Radar Systems

As mentioned in **Part 1**, one way of understanding radar design is to think of the system as a combination of functional blocks that perform key roles (Fig. 2):

- **Common circuit-card assemblies:** Circuit assemblies are responsible for implanting the functions shown in *Figure 2*. Modern common circuit-card assemblies (CCAs) are highly integrated and compact, which accommodates more electronics on a smaller card. There are two common options: digital receiver/exciter CCAs and transmit/receive module CCAs.
- **Digital receiver/exciter (DREX):** DREX is a CCA in modern radar systems, leveraged by both hybrid and fully digital beamforming

arrays. The transit path includes a digital exciter with an integrated waveform generator, a digital-to-analog converter (DAC), and a frequency synthesizer. The receive side has a digital receiver, an analog-to-digital converter (ADC), and a frequency synthesizer. While there's typically an up/down-conversion step, some systems can go direct to digital, and more systems will be expected to do so soon.

- **Transmit/receive (T/R) module:** T/R modules, primarily used in radar systems, are designed to handle both the transmission and reception of radio signals through the same antenna by rapidly switching between modes. Radar systems emit pulses and then "listen" for echoes to determine characteristics of the

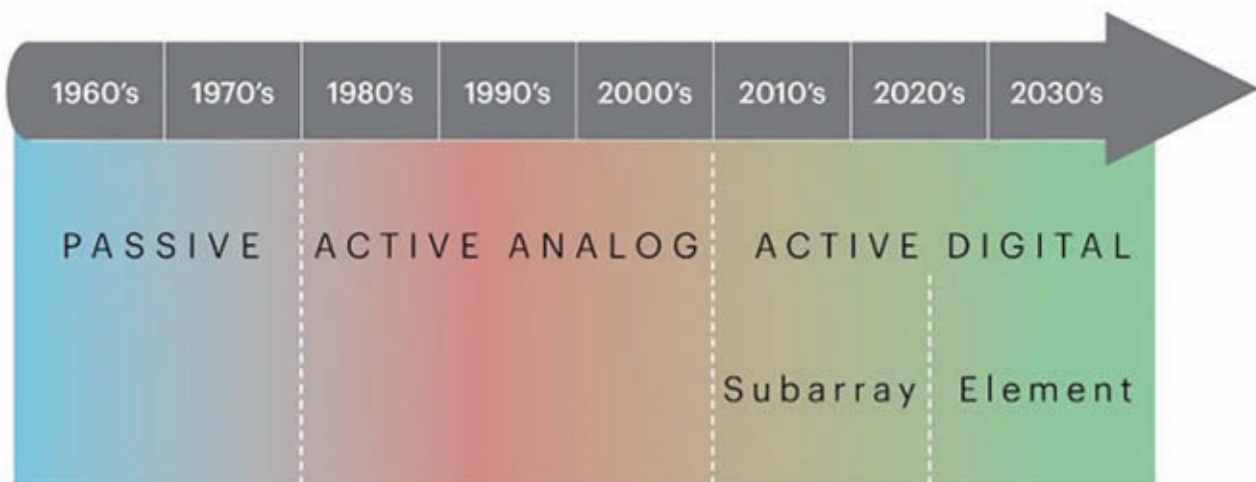

1. The technical evolution of phased-array radar systems has progressed significantly from the 1960s onward. Knowles Precision Devices

target, including range and speed. Many T/R modules are designed and manufactured in-house on a common development platform because their construction depends greatly on the team's approach to packaging and integration.

Advancing Capabilities of Phased-Array Radar

Today, and looking forward, two key trends are driving advances in radar systems: digital architectures and heterogeneous integration. Innovation, enabled by these trends, continues to enhance perfor-

mance, increase flexibility, and improve system integration.

Digital architectures

Advances in radar reflect the need to process more data about the battlespace as quickly as possible and often from the field. Operating mostly in the digital domain enables this to happen with minimal cost and complication.

Digital-array radar is built on phased-array antenna fundamentals. In this new era, transmitted and received energy can be digitized at the element level, so digital-array radar can simultaneously form

multiple receive beams. There are only a few limitations to the number of beams, instantaneous bandwidth, and dynamic range: data converters, digital hardware specifications, and power consumption. As advances emerge in these areas, digital arrays are relevant for applications with higher and higher operating frequencies.

In digital microwave, modern ADCs and better digital-signal-processing (DSP) capabilities facilitated the shift from super-heterodyne to direct sampling, changing the role of the filter to focus on processing in the digital domain and reducing the need for multiple analog stages.

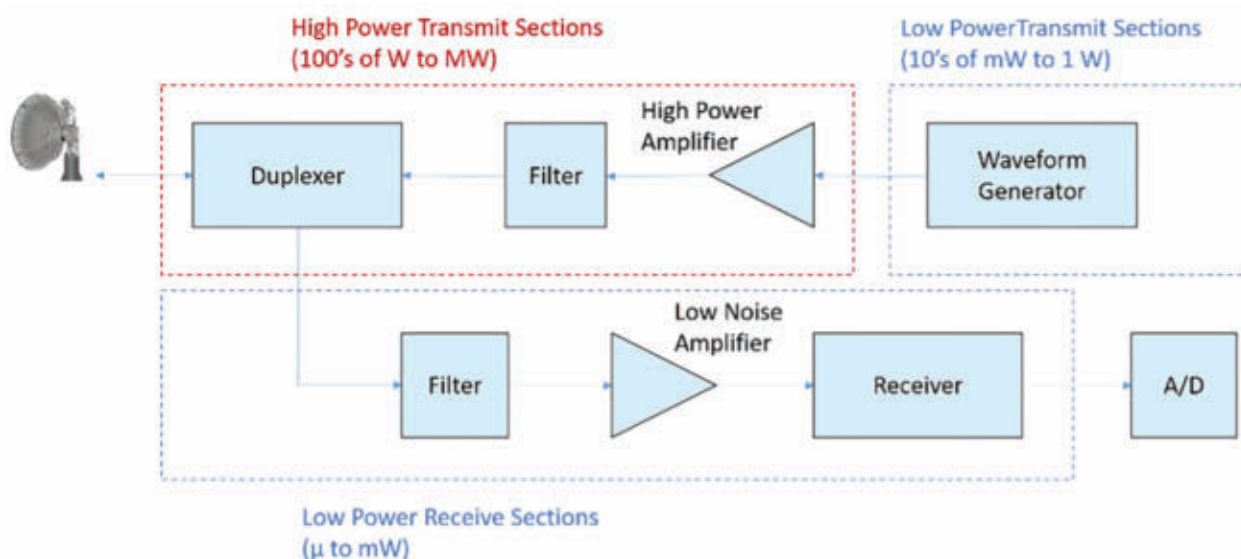

2. Radar systems feature functional blocks that perform key roles. Knowles Precision Devices

As the bandwidth and sampling frequency of RF-ADCs expands, every-element digital receiver/exciter (DREX) modules are becoming more common, too. DREX modules combine ADCs and DSP to perform direct sampling on RF signals at higher frequencies. Without the signal degradation and latency associated with downconversion, the upper frequency limit increases for direct sampling.

To access the potential benefits of integrated devices in a digital-at-every-element approach, all components need to fit within an array pitch, often considered half of the free-space wavelength ($\lambda/2$) of the radiation. In other words, for the X-band, this is 12.5 mm (just under half an inch). In principle, every function from the T/R module through DREX needs to fit into a rectangular cuboid that would measure at most $\lambda/2$ square in the axes parallel to the face of the array.

Heterogeneous integration

As mentioned above, digital architectures have created more demand for small, well-integrated components. Heterogeneous integration (HI) enables several radar functions to combine in one compact, high-performance device.

While this trend is a result of the growing interest in digital architectures, it's inspired a new approach to building these systems, where fewer components are available to purchase and integrate. Examples of this idea exist today—consider the DREX modules mentioned above, synthesizer modules, and T/R modules of the world.

For these integrated devices to be most functional in radar applications, they need to meet certain criteria. For instance, they need to be easily customizable. This becomes possible with the necessary supporting components, namely a tightly integrated semiconductor.

Today, CCAs are still considered large and expensive compared to the promise of an integrated package that contains all relevant components for an antenna element. Given the amalgamation of

demands, we expect to see further interest in HI approaches to building systems.

Heterogeneous Integration in RF and Microwave Design

Integrated passive devices (IPDs), like capacitors, conductors, and resistors, are largely responsible for the performance optimizations that result when components combine in HI. In other words, HI-based designs rely on the performance and manufacturing optimization of IPDs. As these components become more and more advanced, here are a few changes you can expect:

- **Performance improvements:** Changes to the bill of materials (BOM) and underlying technologies can have larger impacts on performance. For example, in radar applications, amplifiers and oscillators are more efficient when designed with materials like gallium arsenide (GaAs), gallium nitride (GaN), and silicon (Si). IPDs offer lower parasitic effects, tighter tolerances, and more consistent temperatures than discrete components. Some are specially designed to improve EMI performance in dense electronics.
- **Higher functional density:** By design, HI increases functional density. The result is smaller and lighter devices, and with a mix of digital and analog components, engineers have the support and capacity they need to create more complex systems.
- **Lower costs:** Minimizing the number of separate components and assembly steps can reduce overall costs. IPDs integrate components for a simpler design process, which translates to a simpler BOM and a less involved manufacturing strategy. This combination reduces time-to-market and production costs.
- **Higher reliability:** Reducing the number of interconnects and solder joints in a design reduces failure points. With fewer failure points and fewer discrete components, IPDs can be designed with robust materials

that can stand up to harsh operating environments over time.

Raising the Bar for Electronic Components in Radar Applications

Radar systems are being asked to do more with less—a smaller footprint in terms of size, weight, power, and cost (SWaP-c), so the defense industry is looking toward small, multifunctional devices that can manage in the digital domain. As a result, there's a new set of standards for those supplying components for radar systems.

Component manufacturers need to:

- Design to fit within $\lambda/2$.
- Focus on high Q and low loss.
- Plan for seamless integration with other parts and functions of the assembly.

As radar systems evolve to meet modern demands, the value of low-loss, high-efficiency components can't be overstated. With the shift toward element-level digital phased arrays, enhanced by HI, it's imperative that IPDs can support them with high reliability and efficiency. Optimizing SWaP-c will remain an important aspect of delivering radar systems that are capable of unprecedented precision and efficiency in challenging scenarios. ■



Signal Generator Spans 0.1 to 44.0 GHz

Mini-Circuits' model SSG-44GHP-RC is a compact signal generator with a frequency range of 0.1 to 44.0 GHz and 1-Hz tuning resolution. Well-suited for 5G FR1 and FR2 band testing, the 50- Ω source generates continuous-wave (CW) as well as pulsed signals with minimum pulse width of 0.5 μ s and 0.65-ms settling time. It offers +23 dBm output power to 22 GHz and +17 dBm to 44.0 GHz with -30 dBc typical harmonics and includes USB and Ethernet interfaces.

MINI-CIRCUITS

<https://tinyurl.com/yss9kz77>

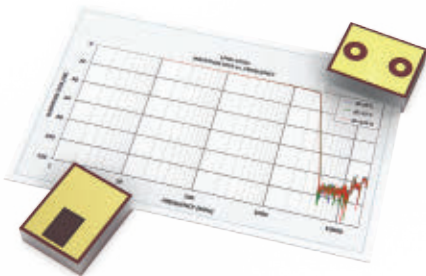

Low-Pass Filter Rejects Signals to 46 GHz

Mini-Circuits' model LFHK-3800+ is a low-pass filter with low-loss passband of DC to 3.8 GHz and stopband to 46 GHz. Based on low-temperature cofired-ceramic (LTCC) technology, the filter has typical passband insertion loss of 1 dB and return loss of 13 dB. Stopband rejection is typically 32 dB from 5.8 to 8.3 GHz, 70 dB from 8.3 to 25.0 GHz, and 37 dB or better to 46.0 GHz. The filter handles as much as 9.5 W power in a 1008 package.

MINI-CIRCUITS

<https://tinyurl.com/25f7mo6t>

Virtual Antenna Supports Multiple Standards

Ignion's Virtual Antenna design is an alternative to the more common flexible printed circuit (FPC), also known as a "sticker antenna." The FPC, with its adhesive backing strip and



cable, is used in compact IoT wireless applications. FPCs require precise cable routing and assembly to deliver optimum performance. Improper design or assembly can result in suboptimal performance in the field. The Virtual Antenna technology is designed to support multi-band, multi-protocol antenna solutions.

IGNION

<https://tinyurl.com/276x4ns8>



Out-of-the-Box Solution Delivers Instant Indoor Wireless Connectivity

Advanced RF Technologies recently released the SDR Series, a Part 20 repeater that can bring immediate wireless connectivity to small- and mid-sized buildings. It facilitates

the provision of cellular coverage by streamlining the often-cumbersome process when establishing in-building wireless networks. Equipped with four 4G/LTE RF bands as well as donor and server antenna, the SDRC package can be easily deployed to improve the existing wireless network. Upgrades are simplified thanks to its modular architecture. The SDRC offers quad-band service in one chassis with digital filtering to significantly decrease the likelihood of interfering with adjacent mobile carrier macro networks.

ADVANCED RF TECHNOLOGIES

<https://tinyurl.com/245tw88m>

USB Peripheral Controller Claims First 20-Gb/s Connectivity

Advanced portable and wearable wireless devices need a good device interface for fast charging and data transfer. Addressing this demand, Infineon Technologies launched the EZ-USB FX20 programmable USB peripheral controller. It opens the door to the creation of USB devices for the demanding requirements in AI, image processing, and emerging applications. Offering high-speed connectivity with USB 20-Gb/s and LVDS interfaces, the EZ-USB FX20 has a bandwidth that's up to 6X greater than legacy devices.



INFINEON TECHNOLOGIES

<https://tinyurl.com/2yjmjply>

Sponsored Content



DS INSTRUMENTS

Founded 2012 | D-U-N-S Number: 079489002 | CAGE Code: 76JK0

WEB | www.dsinstruments.com
EMAIL | support@dsinstruments.com
TEL | 805-242-6685

788 Rubio Way
Gardnerville, NV 89460

BRINGING HIGH-FREQUENCY AND VALUE TO ENGINEERS EVERYWHERE

DS Instruments was founded on the idea that by combining modern semiconductors and innovative designs, microwave equipment could be made more affordable, bringing high-frequency research into the reach of a wider audience. We have been developing equipment that provides universities, defense projects, and communications engineers intuitive, compact solutions at an amazing price point. Being an American manufacturer we stand by our warrantee. We pride ourselves on non-outsourced genuine engineer-to-engineer tech support. As a flexible small business, our design cycle is extremely fast-paced, resulting in cutting-edge semiconductors powering our products within months. Device customization and additional features are happily welcomed and refreshingly affordable.

FLEXIBILITY SETS US APART

Our affordable multi-control devices combine industry standard SCPI remote operation (USB & LAN) with simple and intuitive stand-alone front panel controls. DS Instruments currently specializes in developing compact Signal Generators, Programmable Digital Attenuators, Hybrid RF Mixers, Microwave Amplifiers, and Phase Shifters, with new products released regularly. *Visit us online for updates!*



2025 AND THE FUTURE

The coming year will even more exciting than the last for DS Instruments. Releasing to market new 40GHz products and updated versions including: more powerful amplifiers, more refined integrated-LO mixers, and lower-harmonic-content signal generators. *Call us for a quote!*



DS INSTRUMENTS
WWW.DSINSTRUMENTS.COM



DS INSTRUMENTS

WWW.DSINSTRUMENTS.COM



30GHz Microwave Generator

- Frequency range of 100MHz - 30GHz
- High power output (+15dBm)
- Oven-controlled 10MHz reference clock
- Low phase-noise and harmonic filtering
- Simple Windows control software
- USB & Ethernet SCPI remote commands
- Compact and portable at 4 inches wide!
- Similar models for 6, 12, 22, and 40GHz!

Only \$5199



Digital Step Attenuators

- Frequency Bands: 6, 13, 24, and 30GHz
- 0 to 64dB of attenuation
- 0.5 and 0.25dB resolution options
- USB powered / SCPI command support
- Ethernet connection available
- Simple PC control application
- Stress-tested for absolute reliability
- Extremely compact and affordable

From \$499



Integrated-LO Mixer Family

- 2.5, 6, 12, 20, 30, and 40GHz models
- Programmable local oscillator
- Internal precision reference sources
- Low phase-noise and conversion-loss
- High isolation and linearity
- USB powered and controlled
- Extremely cost and space efficient!

From \$599



Wideband RF Switches

- 6, 26, and 30GHz models
- Non-reflective topology
- Low insertion loss
- SPDT and SP4T models
- Solid-state reliability and speed
- Bi-directional design
- Optional Ethernet connection

From \$499



Digital Phase Shifters

- Models covering 400MHz - 18GHz
- 1/2 & 5-degree phase resolution
- Full 360-degree range
- USB powered / controllable
- Bright OLED display and buttons
- Tiny, rugged, all-metal design
- Ethernet remote control

From \$599

Saving Time and Resources from DC - 40GHz



WWW.DSINSTRUMENTS.COM

(805) 242-6685





COPPER MOUNTAIN® TECHNOLOGIES

About CMT

Founded in 2011 and headquartered in Indianapolis, Indiana, CMT is known for delivering high-performance RF test and measurement equipment and has transformed from a startup into a trusted leader in metrology-grade Vector Network Analyzers (VNAs). Starting in 2020, in partnership with the State of Indiana, CMT has grown its team and re-shored its manufacturing to counter the effects of the COVID pandemic and global instability.

Our mission is to **make RF testing more accessible, efficient, and cost-effective** for engineers worldwide. CMT's product line includes over **30 instruments and VNA solutions** in configurations up to 16-ports, measuring in frequency ranges up to 330 GHz, with options for direct receiver access, frequency extension, pulse measurement, and software compatibility for Windows and Linux OS.

CMT provides superior customer value through an unparalleled combination of partnership, performance, and price. More than just a tool, CMT's VNAs come with comprehensive support, from application engineering and system troubleshooting to customer service that spans the product's lifecycle.

"I'd say the technical support has been the separator, CMT's support team was very patient and helpful as they walked me through all my questions. They also provided custom Python scripts that resolved my issue and made automation trivial."

— **Andrew Betts, Butterfly Network**

Partnership

CMT's expert engineers work as an **extension of your team** to ensure the best implementation of your measurement system. Timely support is included as part of our **total VNA solution**. Our team supplies automation scripts and programming manuals, assists with system integration, performs remote demonstrations, and helps with the design, development, and implementation of your measurements. In addition to our Indianapolis headquarters, we offer global support with international sales offices, as well as an R&D and service center at CMT Europe in Cyprus, which provides another convenient repair and calibration location to customers worldwide.

Performance

The relentless pursuit of innovation, combined with adaptable product offerings, makes CMT an essential partner for companies aiming for precision in an increasingly interconnected world. The VNAs are designed for easy customization to deliver **high-performing insertable measurement modules** for unique applications. The versatility of CMT VNAs, some small enough to fit in one's hand, has enabled successful integration into NASA space station fuel systems, a breast cancer detection system, ultrasound technology, crop moisture and ripeness sensors, and various R&D projects.

Price

CMT's VNAs empower engineers to achieve previously impossible goals, giving more users access to high-quality instrumentation at an affordable cost. The **FREE** VNA software features an intuitive user interface and can be installed without a license. Advanced software features, such as time domain reflectometry and gating, frequency offset, TRL Calibration, etc., come at no additional cost, enabling **maximum functionality for ALL users**.

Metrology-grade Vector Network Analyzers

Measurements from 9 kHz to 330 GHz

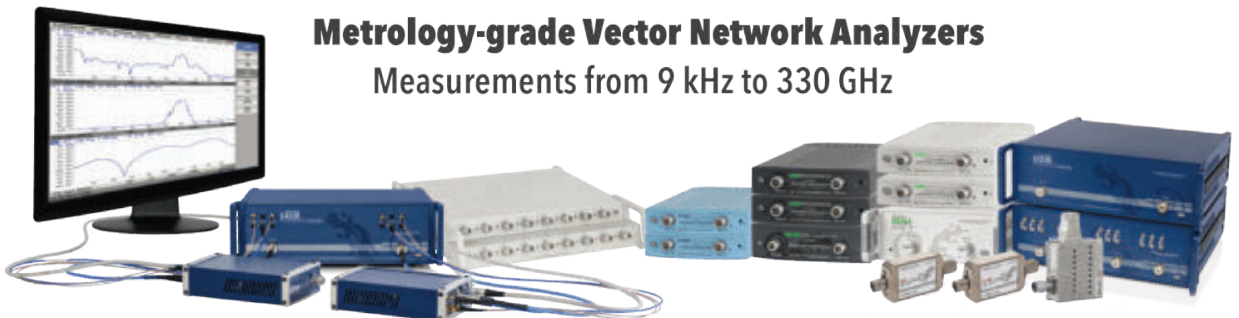

LEADER IN CUSTOMER VALUE

VECTOR NETWORK ANALYZERS

VALUE

- Metrology-grade performance backed by CMT's ISO/IEC 17025 (2017) accredited lab.
- Advanced software features in **Windows or Linux OS** included.
- **Timely Support** from automation and applications engineers who function as part of your team to help configure and optimize measurements.
- **Made in the USA.**

Sign up for a free instrument trial today and experience value firsthand.



AVAILABLE AS INSERTABLE MODULES



1-Port VNAs from CMT

Reflectometers, or 1-Port VNAs, are able to *connect directly to a DUT* to eliminate cable instability. These VNAs are *ideal for cable, antenna, materials measurements, etc.* in or out of the lab. They are *fully programmable* and ideal for automating test.



 **EXTEND YOUR REACH[®]**

WWW.COPPERMOUNTAINTECH.COM



**COPPER MOUNTAIN
TECHNOLOGIES**

**Electronic
Design**

**Machine
Design**

Microwaves & RF

**POWER
& MOTION**

**Military + Aerospace
Electronics**

**LASER FOCUS
WORLD**

**VISION
SYSTEMS DESIGN**

**EDGE
AWARDS**

CONGRATULATIONS!

**Thank you to the voters for helping to select this year's EDGE Awards
Winners & Honorees from the following categories:**

**Automation & Controls | Communication | Computing Hardware, Software & Systems
Electronic Components & Enclosures | Machine Learning/Deep Learning
Machine Vision & Inspection | Robotics & Motion Control | Optical & Photonics**

Our Leading Edge Winner for 2024 with the most votes overall is the Green Cubes Technology 48-V Industrial Swappable Battery, specifically designed for fast or hot-swapping batteries in everything from mobile workstations to industrial mobile robots.

**Learn more about Green Cube
Technology's 48-V Industrial
Swappable Battery**

www.electronicdesign.com/55094061



**To read about all of our
Winners and Honorees, head to**
www.electronicdesign.com/55140401



**Special thanks to
our Premier Winners
& Honorees**

COGNEX

Winner of the Machine
Vision & Inspection category
for its In-Sight L38

Nordson
EFD

Winner of the Automation &
Controls category for its
PICO Nexus Jetting System

synaptics

Winner of the Machine Learning/
Deep Learning category for its Astra
AI-Native Edge IoT Platform